

NEW

# Brushless DC-Gearmotors

## 30 mNm

For combination with  
Speed Controller:  
SC 1801

### Series 1515 ... B

	1515 U	006 B	012 B	
1 Nominal voltage	U <sub>N</sub>	6	12	Volt
2 Terminal resistance, phase-phase	R	22,0	92,8	Ω
3 Output power	P <sub>2 max.</sub>	0,31	0,30	W
4 Efficiency	η <sub>max.</sub>	56	55	%
5 No-load speed	n <sub>0</sub>	14 700	14 700	rpm
6 No-load current	I <sub>0</sub>	0,0174	0,0087	A
7 Stall torque	M <sub>H</sub>	0,97	0,92	mNm
8 Friction torque, static	C <sub>0</sub>	0,025	0,025	mNm
9 Friction torque, dynamic	C <sub>v</sub>	2,6 · 10 <sup>-6</sup>	2,6 · 10 <sup>-6</sup>	mNm/rpm
10 Speed constant	k <sub>n</sub>	2 623	1 312	rpm/V
11 Back-EMF constant	k <sub>E</sub>	0,381	0,762	mV/rpm
12 Torque constant	k <sub>M</sub>	3,64	7,28	mNm/A
13 Current constant	k <sub>I</sub>	0,275	0,137	A/mNm
14 Slope of n-M curve	Δn/ΔM	15 856	16 721	rpm/mNm
15 Terminal inductance, phase-phase	L	590	2 350	μH
16 Mechanical time constant	τ <sub>m</sub>	115	121	ms
17 Rotor inertia	J	0,69	0,69	gcm <sup>2</sup>
18 Angular acceleration	α <sub>max.</sub>	14	13	·10 <sup>3</sup> rad/s <sup>2</sup>
19 Thermal resistance	R <sub>th 1</sub> / R <sub>th 2</sub>	65 / 45		K/W
20 Thermal time constant	τ <sub>w1</sub> / τ <sub>w2</sub>	10 / 130		s

### Integrated Gearhead

Housing material		plastic	
Geartrain material		metal	
Backlash, at no-load	≤	4	°
Bearings on output shaft		plastic / brass bearing	
Shaft load max.:			
– radial (5 mm from mounting face)	≤	1,4	N
– axial	≤	0,3	N
Shaft press fit force, max.	≤	5	N
Shaft play:			
– radial (5 mm from mounting face)	≤	0,08	mm
– axial	≤	0,25	mm
Operating temperature range		– 25 ... + 80	°C

### Specifications

reduction ratio (rounded)	output speed up to n <sub>max</sub> rpm	weight with motor g	output torque		direction of rotation (reversible)	efficiency %
			continuous operation M <sub>max</sub> mNm	intermittent operation M <sub>max</sub> mNm		
6 : 1	779	6,9	1,4	3	=	81
13 : 1	372	7,0	2,8	5	≠	73
39 : 1	129	7,2	7,0	10	=	60
112 : 1	45	7,4	19,8	30	≠	59
324 : 1	15	7,7	30,0	50	=	53

**1515 U ... B**

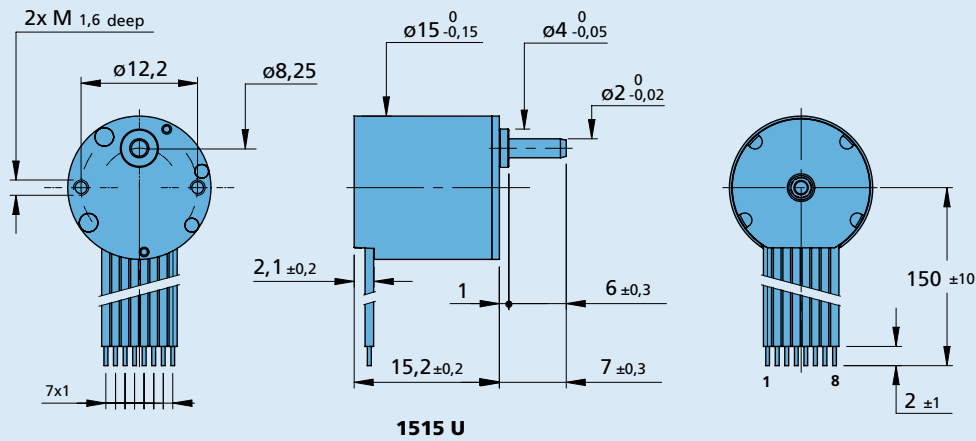
 Scale enlarged 

**Connection**

No.	Function
1	Phase C
2	Phase B
3	Phase A
4	GND
5	+ 5V
6	Hall sensor C
7	Hall sensor B
8	Hall sensor A