

Brushless DC-Servomotors

4 Pole Technology

19 mNm

For combination with
 Gearheads:
 22F, 22/7, 26A
 Encoders:
 2232...BX4 + Encoder
 Drive Electronics:
 Speed Controller

Series 2232 ... BX4

	2232 S	012 BX4	024 BX4	
1 Nominal voltage	U_N	12	24	Volt
2 Terminal resistance, phase-phase	R	3,5	12,4	Ω
3 Output power ¹⁾	$P_2 \text{ max.}$	7,6	7,7	W
4 Efficiency	$\eta \text{ max.}$	66,9	67,6	%
5 No-load speed	n_0	6 600	7 000	rpm
6 No-load current (with shaft \varnothing 3,0 mm)	I_0	0,112	0,061	A
7 Stall torque	M_H	55,7	59,9	mNm
8 Friction torque, static	C_0	0,85	0,85	mNm
9 Friction torque, dynamic	C_v	$1,5 \cdot 10^{-4}$	$1,5 \cdot 10^{-4}$	mNm/rpm
10 Speed constant	k_n	579	304	rpm/V
11 Back-EMF constant	k_E	1,728	3,288	mV/rpm
12 Torque constant	k_M	16,50	31,40	mNm/A
13 Current constant	k_I	0,061	0,032	A/mNm
14 Slope of n-M curve	$\Delta n / \Delta M$	123	120	rpm/mNm
15 Terminal inductance, phase-phase	L	120	440	μH
16 Mechanical time constant	τ_m	6,7	6,5	ms
17 Rotor inertia	J	5,2	5,2	gcm^2
18 Angular acceleration	$\alpha \text{ max.}$	107	115	$\cdot 10^3 \text{ rad/s}^2$
19 Thermal resistance	$R_{th 1} / R_{th 2}$	2 / 17		K/W
20 Thermal time constant	τ_{w1} / τ_{w2}	4,1 / 370		s
21 Operating temperature range		- 40 ... + 100		$^{\circ}\text{C}$
22 Shaft bearings		ball bearings, preloaded		
23 Shaft load max.:				
– radial at 3 000 rpm (4 mm from mounting flange)		20		N
– axial at 3 000 rpm		2		N
– axial at standstill		20		N
24 Shaft play:				
– radial	\leq	0,015		mm
– axial	\equiv	0		mm
25 Housing material		stainless steel		
26 Weight		70		g
27 Direction of rotation		electronically reversible		
28 Number of pole pairs		2		
Recommended values - mathematically independent of each other				
29 Speed up to	$n_e \text{ max.}$	22 000	22 000	rpm
30 Torque up to ^{1) 2)}	$M_e \text{ max.}$	12 / 19	12 / 19	mNm
31 Current up to ^{1) 2)}	$I_e \text{ max.}$	0,90 / 1,40	0,48 / 0,74	A

¹⁾ at 5 000 rpm

²⁾ thermal resistance $R_{th 2}$ not reduced / thermal resistance $R_{th 2}$ by 55% reduced

Note:

The diagram indicates the recommended speed in relation to the available torque at the output shaft for a given ambient temperature of 22°C.

The diagram shows the motor in a completely insulated as well as thermally coupled condition ($R_{th 2}$ 55% reduced).

The nominal voltage (U_N) curve shows the operating point at nominal voltage in the insulated and thermally coupled condition. Any points of operation above the curve at nominal voltage will require a higher operating voltage. Any points below the nominal voltage curve will require less voltage.

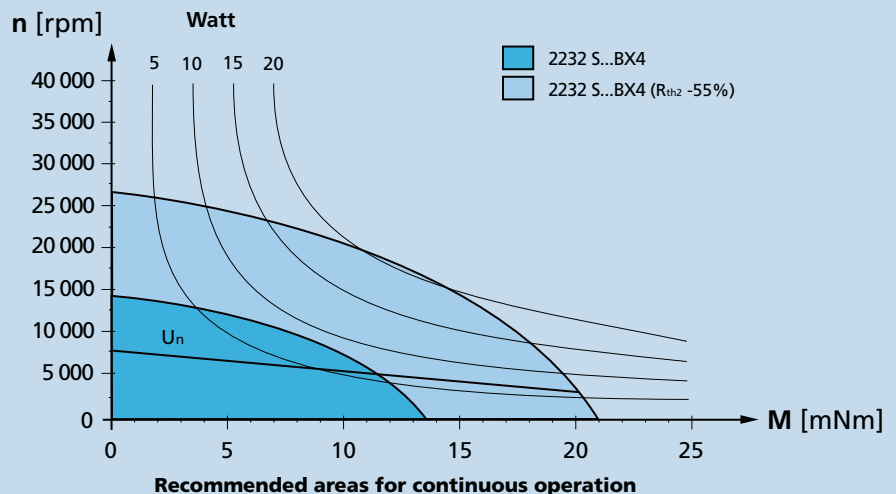

Dimensional drawing

M 1:1

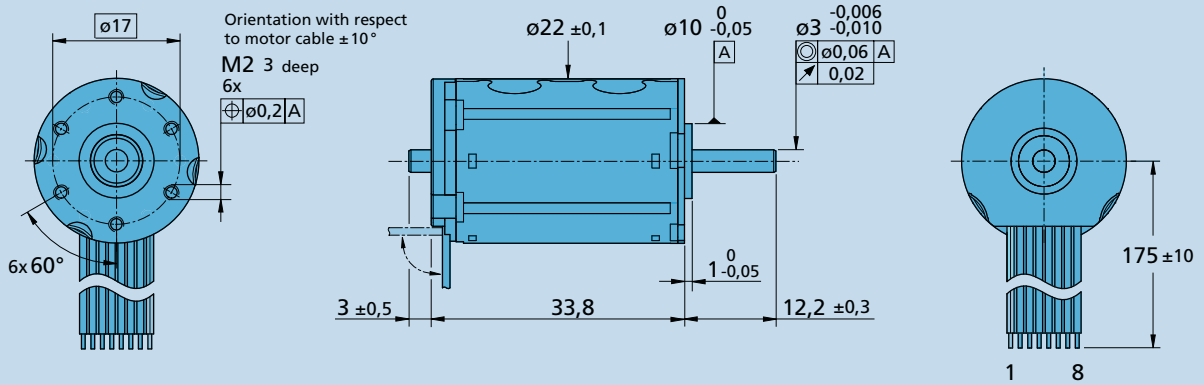

2232 S ... BX4

Options

- Connector variant (Option no. 3830)

Motor:
AWG 26 / PVC ribbon cable
with connector Micro-Fit



- Analog Hall sensors (Option no. 3692)

Full product description

- Examples:
2232S024BX4

Cable and connection information

