

Brushless DC-Servomotors

with integrated Speed Controller

4 Pole Technology

7 mNm

For combination with
Gearheads:
22F, 22/7, 26A

Series 2232 ... BX4 S SC

	2232 S	012 BX4 S	024 BX4 S	SC
1 Nominal voltage	U_N	12	24	Volt
2 Terminal resistance, phase-phase	R	3,5	12,4	Ω
3 Output power ¹⁾	$P_{2 \text{ max.}}$	4,4	4,5	W
4 Efficiency	$\eta_{\text{ max.}}$	60,9	61,7	%
5 No-load speed	n_o	13 200	14 000	rpm
6 No-load current (with shaft \varnothing 3,0 mm)	I_o	0,163	0,088	A
7 Stall torque	M_H	27,3	29,4	mNm
8 Friction torque, static	C_o	0,6	0,6	mNm
9 Friction torque, dynamic	C_v	$5,5 \cdot 10^{-5}$	$5,5 \cdot 10^{-5}$	mNm/rpm
10 Speed constant	k_n	1 173	616	rpm/V
11 Back-EMF constant	k_E	0,852	1,623	mV/rpm
12 Torque constant	k_M	8,14	15,50	mNm/A
13 Current constant	k_I	0,123	0,065	A/mNm
14 Slope of n-M curve	$\Delta n / \Delta M$	504	493	rpm/mNm
15 Terminal inductance, phase-phase	L	130	470	μH
16 Mechanical time constant	τ_m	22	22	ms
17 Rotor inertia	J	4,2	4,2	gcm^2
18 Angular acceleration	$\alpha_{\text{ max.}}$	65	70	$\cdot 10^3 \text{ rad/s}^2$
19 Thermal resistance	$R_{th 1} / R_{th 2}$	2 / 13		K/W
20 Thermal time constant	τ_{w1} / τ_{w2}	4,1 / 274		s
21 Operating temperature range		- 40 ... + 85		$^{\circ}\text{C}$
22 Shaft bearings		ball bearings, preloaded		
23 Shaft load max.:				
– radial at 3 000 rpm (4 mm from mounting flange)		20		N
– axial at 3 000 rpm		2		N
– axial at standstill		20		N
24 Shaft play:				
– radial	\leq	0,015		mm
– axial	\equiv	0		mm
25 Housing material		stainless steel		
26 Weight		77		g
27 Direction of rotation		electronically reversible		
28 Number of pole pairs		2		
Recommended values - mathematically independent of each other				
29 Speed up to	$n_e \text{ max.}$	22 500	17 000	rpm
30 Torque up to ^{1) 2)}	$M_e \text{ max.}$	7	7	mNm
31 Current up to ^{1) 2)}	$I_e \text{ max.}$	0,99	0,52	A

¹⁾ at 5 000 rpm

²⁾ thermal resistance $R_{th 2}$ not reduced

Note:

The diagram indicates the recommended speed in relation to the available torque at the output shaft for a given ambient temperature of 22°C.

The diagram shows the motor in a completely insulated condition.

The motor is factory pre-configured to a continuous current for the thermally insulated condition. The controller must be reconfigured with the easy to use Motion Manager Software for use with other parameter settings.

The nominal voltage (U_N) curve shows the operating point at nominal voltage in the insulated condition. Any points of operation above the curve at nominal voltage will require a higher operating voltage. Any points below the nominal voltage curve will require less voltage.

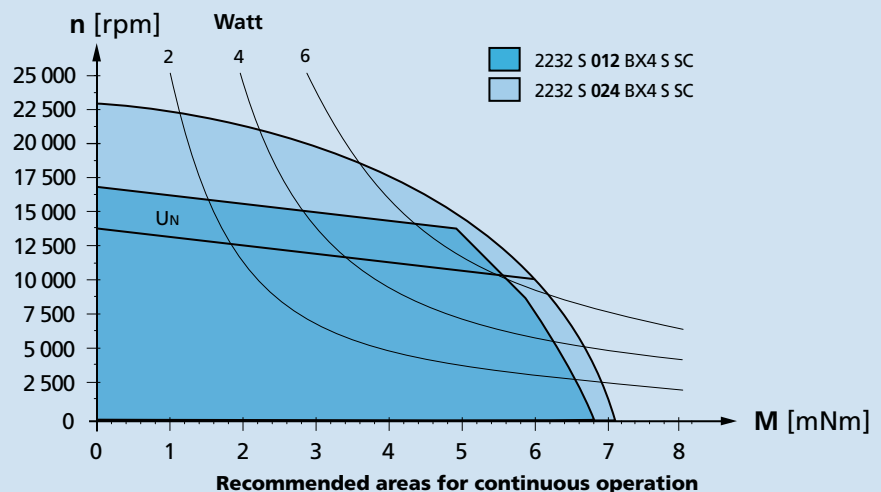

Dimensional drawing

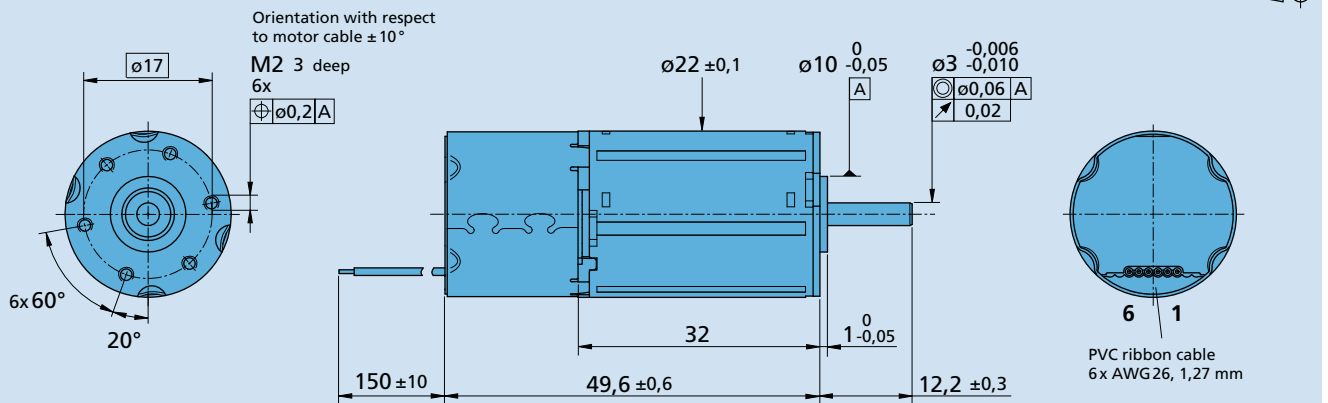

2232 S ... BX4 S SC

Speed Controller		012 BX4 S	024 BX4 S	SC
Power supply electronic	U_p	5 ... 28		V DC
Power supply motor	U_{mot}	6 ... 28		V DC
PWM switching frequency	f_{PWM}	96		kHz
Efficiency	η	95		%
Max. continuous output current ¹⁾	I_{dauer}	1	0,5	A
Max. peak output current	I_{max}	2	1	A
Total standby current	I_{el}	0,020		A
Speed range electronic		400 ... 50 000 ²⁾		rpm
Scanning range		500		μ s

¹⁾ at 22°C ambient temperature and max. 60°C motor temperature respectively

²⁾ speed depend on motor operating voltage

Connection information		012 BX4 S	024 BX4 S	SC
Connection 1 "U _P ":	power supply electronic	U_p		
Connection 2 "U _{mot} ":	power supply electronic coil	U_{mot}		
Connection 3 "GND":	ground	ground		
Connection 4 "U _{nsoll} ":				
- analog input	input voltage	$U_{in} = 0 \dots 10V \mid > 10V \dots U_p \gg$ set speed value not defined		
	input resistance	$R_{in} \geq 5k\Omega$		
	set speed value	per 1V	2 000	2 000 rpm
		$U_{in} < 0,15V \gg$ motor stops		
		$U_{in} > 0,3V \gg$ motor starts		
Connection 5 "DIR":				
- analog input	direction of rotation	to ground or level < 0,5V » counterclockwise		
		open or level > 3V » clockwise		
	input resistance	$R_{in} \geq 10k\Omega$		
Connection 6 "FG":				
- digital output	frequency output	max. U_p ; $I_{max} = 15$ mA; open collector with 22k Ω pull-up resistor		
		6 lines per revolution		

Features

In this variant, the brushless DC servomotors have an integrated Speed Controller. The motor is commutated using Hall sensors integrated into the motor. Speed control is via a PI regulator.

The Speed Controller has a current limiting device which limits the maximum motor current if the thermal load is too high. Twice the continuous current is possible over a short time.

Using the "FAULHABER Motion Manager" software, the customer can modify the Speed Controller to special conditions of use. The following parameters can be changed: current limit and regulator parameters.

Circuit diagram/Connection information

Output circuit

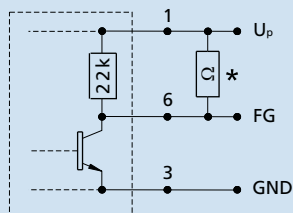

* An additional external pull-up resistor can be added to improve the rise time.
 Caution: I_{out} max. 15 mA must not be exceeded!

Cable connection

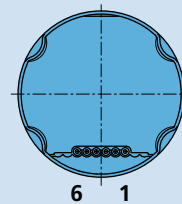

Connection

No.	Function
1	U_p
2	U_{mot}
3	GND
4	U_{soll}
5	DIR
6	FG

Caution:
 Incorrect lead connection will damage the motor electronics!

Options

- Connector variant (Option no.: 3809)
 AWG 26 / PVC ribbon cable with connector Micro-Fit



Accessories

- Programming board (Part No.: 6501.00088)

Full product description

- Example:
 2232S024BX4S SC