

Brushless DC-Servomotors

22 mNm

4 Pole Technology

For combination with
 Gearheads:
 22F, 22/7, 26A
 Encoders:
 2250...BX4S + Encoder
 Drive Electronics:
 Speed Controller

Series 2250 ... BX4 S

	2250 S		024 BX4 S	
1 Nominal voltage	U_N		24	Volt
2 Terminal resistance, phase-phase	R		5,9	Ω
3 Output power ¹⁾	$P_2 \text{ max.}$		8,8	W
4 Efficiency	$\eta \text{ max.}$		70,4	%
5 No-load speed	n_0		10 500	rpm
6 No-load current (with shaft \varnothing 3,0 mm)	I_0		0,105	A
7 Stall torque	M_H		84,7	mNm
8 Friction torque, static	C_0		0,75	mNm
9 Friction torque, dynamic	C_v		$1,4 \cdot 10^{-4}$	mNm/rpm
10 Speed constant	k_n		451	rpm/V
11 Back-EMF constant	k_E		2,218	mV/rpm
12 Torque constant	k_M		21,1	mNm/A
13 Current constant	k_I		0,047	A/mNm
14 Slope of n-M curve	$\Delta n / \Delta M$		125,6	rpm/mNm
15 Terminal inductance, phase-phase	L		250	μH
16 Mechanical time constant	τ_m		6,97	ms
17 Rotor inertia	J		5,3	gcm^2
18 Angular acceleration	$\alpha \text{ max.}$		160	$\cdot 10^3 \text{ rad/s}^2$
19 Thermal resistance	$R_{th 1} / R_{th 2}$	1,2 / 14		K/W
20 Thermal time constant	τ_{w1} / τ_{w2}	4,2 / 443		s
21 Operating temperature range		- 40 ... + 100		$^{\circ}\text{C}$
22 Shaft bearings		ball bearings, preloaded		
23 Shaft load max.:				
- radial at 3 000 rpm (4 mm from mounting flange)		20		N
- axial at 3 000 rpm		2		N
- axial at standstill		20		N
24 Shaft play:				
- radial	\leq	0,015		mm
- axial	\equiv	0		mm
25 Housing material		stainless steel		
26 Weight		90		g
27 Direction of rotation		electronically reversible		
28 Number of pole pairs		2		
Recommended values - mathematically independent of each other				
29 Speed up to	$n_e \text{ max.}$		25 000	rpm
30 Torque up to ^{1) 2)}	$M_e \text{ max.}$		14 / 22	mNm
31 Current up to ^{1) 2)}	$I_e \text{ max.}$		0,79 / 1,20	A

¹⁾ at 5 000 rpm

²⁾ thermal resistance $R_{th 2}$ not reduced / thermal resistance $R_{th 2}$ by 55% reduced

Note:

The diagram indicates the recommended speed in relation to the available torque at the output shaft for a given ambient temperature of 22°C.

The diagram shows the motor in a completely insulated as well as thermally coupled condition ($R_{th 2}$ 55% reduced).

The nominal voltage (U_N) curve shows the operating point at nominal voltage in the insulated and thermally coupled condition. Any points of operation above the curve at nominal voltage will require a higher operating voltage. Any points below the nominal voltage curve will require less voltage.

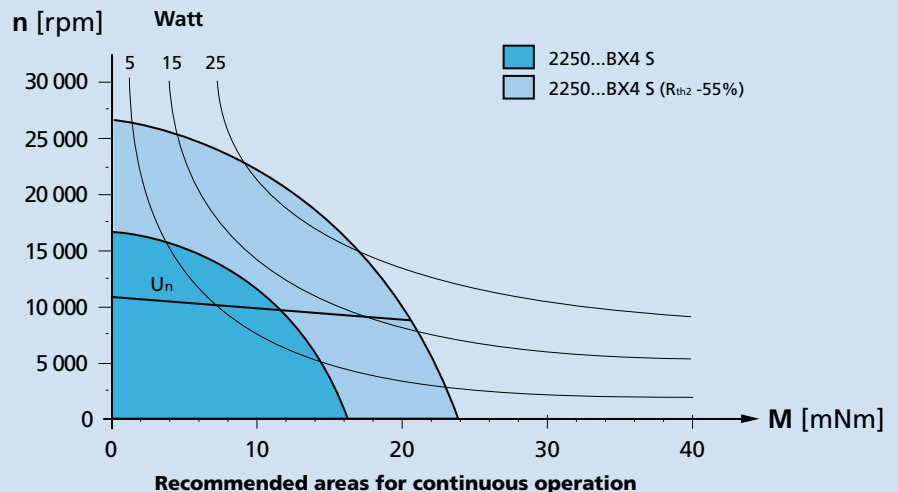

Dimensional drawing

M 1:1

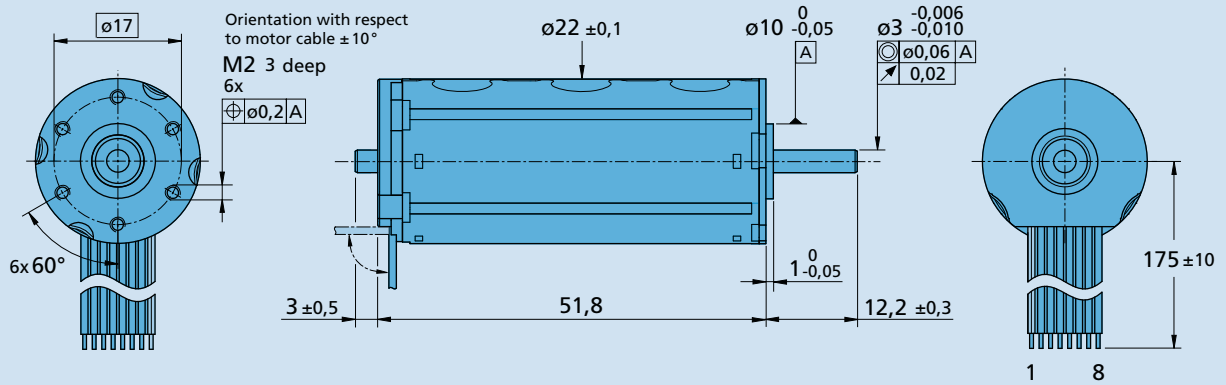

2250 S ... BX4 S

Options

- Connector variant (Option no. 3830)

Motor:
AWG 26 / PVC ribbon cable
with connector Micro-Fit



Full product description

- Examples:
2250S024 BX4S

Cable and connection information

