

Brushless Flat DC-Micromotors

with integrated Speed Controller

3,7 mNm

Series 2610 ... B SC

| | 2610 T | 006 B | 012 B | SC |
|--|---------------------------------------|---------------------------|-------------------------|--------------------------------------|
| 1 Nominal voltage | U _N | 6 | 12 | Volt |
| 2 Terminal resistance, phase-phase | R | 7,0 | 28,2 | Ω |
| 3 Output power ¹⁾ | P _{2 max.} | 1,92 | 1,91 | W |
| 4 Efficiency | η _{max.} | 78 | 78 | % |
| 5 No-load speed | n ₀ | 6 200 | 6 200 | rpm |
| 6 No-load current | I ₀ | 0,012 | 0,006 | A |
| 7 Stall torque | M _H | 7,73 | 7,68 | mNm |
| 8 Friction torque, static | C ₀ | 0,025 | 0,025 | mNm |
| 9 Friction torque, dynamic | C _v | 1,35 · 10 ⁻⁵ | 1,35 · 10 ⁻⁵ | mNm/rpm |
| 10 Speed constant | k _n | 1 055 | 528 | rpm/V |
| 11 Back-EMF constant | k _E | 0,948 | 1,895 | mV/rpm |
| 12 Torque constant | k _M | 9,05 | 18,1 | mNm/A |
| 13 Current constant | k _I | 0,111 | 0,055 | A/mNm |
| 14 Slope of n-M curve | Δn/ΔM | 816 | 822 | rpm/mNm |
| 15 Terminal inductance, phase-phase | L | 480 | 1 940 | μH |
| 16 Mechanical time constant | τ _m | 69 | 70 | ms |
| 17 Rotor inertia | J | 8,1 | 8,1 | gcm ² |
| 18 Angular acceleration | α _{max.} | 9,5 | 9,5 | · 10 ³ rad/s ² |
| 19 Thermal resistance | R _{th 1} / R _{th 2} | 33 / 27 | | K/W |
| 20 Thermal time constant | τ _{w1} / τ _{w2} | 20 / 230 | | s |
| 21 Operating temperature range | | -25 ... +80 | | °C |
| 22 Shaft bearings | | ball bearing, preloaded | | |
| 23 Shaft load max.: | | | | |
| – radial at 3 000/7 000 rpm (3 mm from mounting flange) | | 4,0 / 3,5 | | N |
| – axial at 3 000/7 000 rpm (push-on only) | | 3,5 / 3,4 | | N |
| – axial at standstill (push-on only) | | 17,5 | | N |
| 24 Shaft play: | | | | |
| – radial | ≤ | 0,015 | | mm |
| – axial | = | 0 | | mm |
| 25 Housing material | | plastic | | |
| 26 Weight | | 20,1 | | g |
| 27 Direction of rotation | | electronically reversible | | |
| Recommended values - mathematically independent of each other | | | | |
| 28 Speed up to | n _{e max.} | 7 000 | 7 000 | rpm |
| 29 Torque up to ^{1) 2)} | M _{e max.} | 3,14 / 3,72 | 3,13 / 3,70 | mNm |
| 30 Current up to ^{1) 2)} | I _{e max.} | 0,403 / 0,475 | 0,201 / 0,236 | A |

¹⁾ at 5 000 rpm

²⁾ thermal resistance R_{th 2} not reduced / thermal resistance R_{th 2} by 55% reduced

Note:

The diagram indicates the recommended speed in relation to the available torque at the output shaft for a given ambient temperature of 22°C.

The diagram shows the motor in a completely insulated as well as thermally coupled condition (R_{th 2} 55% reduced).

The area of the curve is defined by the maximum allowable supply voltage of the integrated speed controller as well as the control performance characteristics.

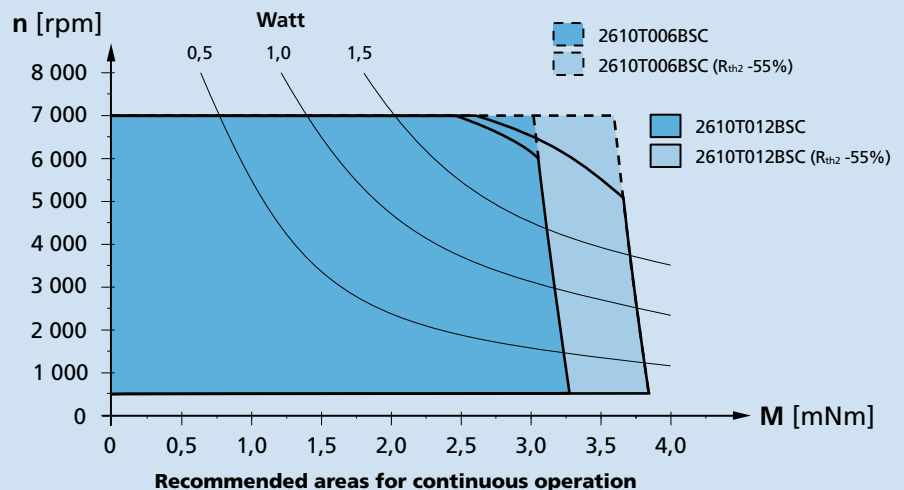

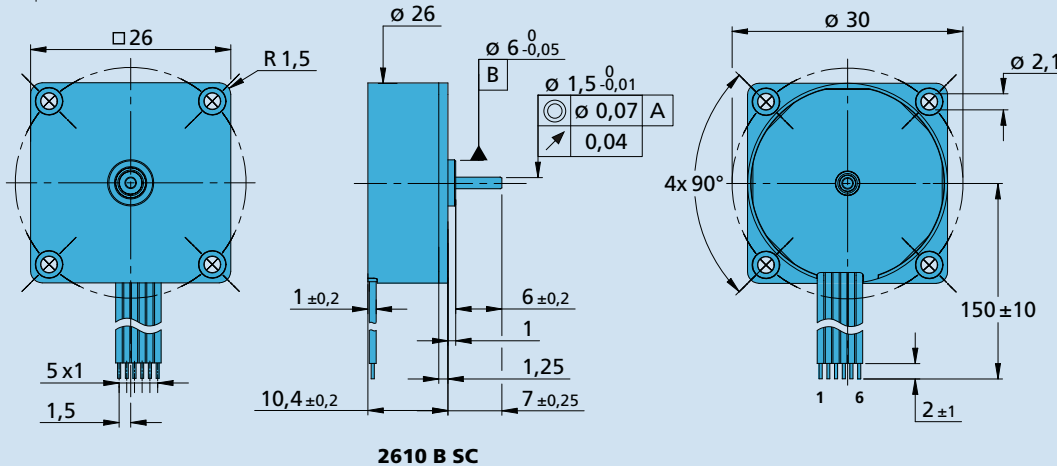
2610 T ... B SC
 M1:1

Option

- connector variants AWG 28 / PVC ribbon cable with connector Picoblade

connector pin assignment:

Connection

| No. | Function |
|-----|------------------|
| 1 | Up |
| 2 | U _{mot} |
| 3 | GND |
| 4 | Unsoll |
| 5 | DIR |
| 6 | FG |

| Speed Controller | 006 B | 012 B | SC |
|--|------------------------------|-------|-----|
| PWM switching frequency | 96 | 96 | kHz |
| Efficiency | 95 | 95 | % |
| Max. continuous output current ¹⁾ | 0,8 | 0,8 | A |
| Max. peak output current | 1,6 | 1,6 | A |
| Total standby current | 0,020 | | A |
| Speed range electronic | 500 ... 60 000 ²⁾ | | rpm |
| Scanning range | 500 | | µs |

¹⁾ at 22°C ambient temperature and max. 60°C motor temperature respectively

²⁾ speed depend on motor operating voltage

| Connection information | 006 B | 012 B | SC |
|---|--|-------|-------------------------|
| Connection 1 "U_P": power supply electronic | U _P = 4 ... 18 V | | |
| Connection 2 "U_{mot}": power supply electronic coil | U _{mot} = 1,7 ... 18 V | | |
| Connection 3 "GND": ground | ground | | |
| Connection 4 "Unsoll": | | | |
| – analog input | input voltage input resistance set speed value | | |
| | U _{in} = 0 ... 10V (max. U _P) R _{in} ≥ 8 kΩ per 1V 1 000 1 000 | | rpm |
| | U _{in} < 0,15V » motor stops U _{in} > 0,3V » motor starts | | |
| Connection 5 "DIR": | | | |
| – analog input | direction of rotation | | |
| | to ground or level < 0,5V » counterclockwise open or level > 3V » clockwise (max. U _P) | | |
| | input resistance | | R _{in} ≥ 10 kΩ |
| Connection 6 "FG": | | | |
| – digital output | frequency output | | |
| | with max. U _P » I _{max} = 15 mA; open collector with 22 kΩ pull-up resistor | | |
| | 6 lines per revolution | | |

Features

In this variant, the brushless DC-Micromotors have an integrated Speed Controller. The motor is commutated using Hall sensors integrated into the motor. Speed control is via a PI regulator. The Speed Controller has a current limiting device which limits the maximum motor current if the thermal load is too high. Twice the continuous current is possible over a short time.

Using the "FAULHABER Motion Manager" software, the customer can modify the Speed Controller to special conditions of use.

The following parameters can be changed: current limit and regulator parameters.

Full product description

- Examples:

2610T006B SC
2610T012B SC