

# DC-Micromotors

## Precious Metal Commutation

### 4,2 mNm

For combination with  
 Gearheads:  
 15A, 16/7, 16A  
 Encoders:  
 IE2-1024, IE2-16

### Series 1724 ... SR

	1724 T	003 SR	006 SR	012 SR	018 SR	024 SR		
1 Nominal voltage	$U_N$	3	6	12	18	24	V	
2 Terminal resistance	R	0,78	3,41	16,2	32,1	54,6	$\Omega$	
3 Output power	$P_{2 \max}$	2,83	2,58	2,17	2,47	2,58	W	
4 Efficiency, max.	$\eta_{\max}$	82	81	80	81	81	%	
5 No-load speed	$n_0$	8 200	8 600	7 900	8 400	8 600	rpm	
6 No-load current (with shaft $\varnothing$ 1,5 mm)	$I_0$	0,038	0,02	0,009	0,006	0,005	A	
7 Stall torque	$M_H$	13,2	11,5	10,5	11,2	11,5	mNm	
8 Friction torque	$M_R$	0,13	0,13	0,13	0,12	0,13	mNm	
9 Speed constant	$k_n$	2 760	1 450	666	472	362	rpm/V	
10 Back-EMF constant	$k_E$	0,362	0,69	1,5	2,12	2,76	mV/rpm	
11 Torque constant	$k_M$	3,46	6,59	14,3	20,2	26,3	mNm/A	
12 Current constant	$k_i$	0,289	0,152	0,07	0,049	0,038	A/mNm	
13 Slope of n-M curve	$\Delta n / \Delta M$	621	748	752	750	748	rpm/mNm	
14 Rotor inductance	L	21	75	360	710	1 200	$\mu$ H	
15 Mechanical time constant	$\tau_m$	8	8	8	8	8	ms	
16 Rotor inertia	J	1,2	1	1	1	1	gcm <sup>2</sup>	
17 Angular acceleration	$\alpha_{\max}$	110	110	100	100	100	$\cdot 10^3 \text{rad/s}^2$	
18 Thermal resistance	$R_{th 1} / R_{th 2}$	4 / 24,5						K/W
19 Thermal time constant	$\tau_{w1} / \tau_{w2}$	2,6 / 270						s
20 Operating temperature range:		-30 ... +85 (optional version -55 ... +125)						°C
- motor								
- rotor, max. permissible		+125						°C
21 Shaft bearings		sintered bearings	ball bearings	ball bearings, preloaded				
22 Shaft load max.:		(standard)	(optional version)	(optional version)				
- with shaft diameter		1,5	1,5	1,5			mm	
- radial at 3 000 rpm (3 mm from bearing)		1,2	5	5			N	
- axial at 3 000 rpm		0,2	0,5	0,5			N	
- axial at standstill		20	10	10			N	
23 Shaft play								
- radial	$\leq$	0,03	0,015	0,015			mm	
- axial	$\leq$	0,2	0,2	0			mm	
24 Housing material		steel, black coated						
25 Weight		27						g
26 Direction of rotation		clockwise, viewed from the front face						
<b>Recommended values - mathematically independent of each other</b>								
27 Speed up to	$n_{e \max}$	8 000	8 000	8 000	8 000	8 000	rpm	
28 Torque up to	$M_{e \max}$	4,2	4,2	4,2	4,2	4,2	mNm	
29 Current up to (thermal limits)	$I_{e \max}$	1,6	0,76	0,35	0,25	0,19	A	

Orientation with respect to motor terminals not defined

6x  $\varnothing 0,3$  A M1,6 1,6 deep

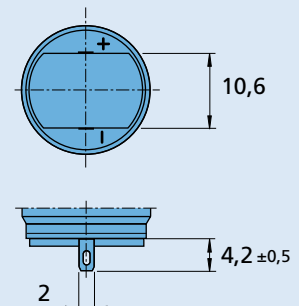
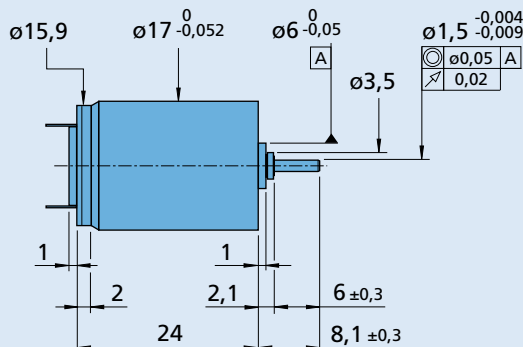
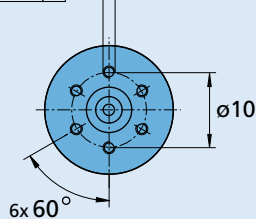

1724 T ... SR