

# Motion Controller

4-Quadrant PWM  
with RS232 or CAN interface

For combination with:  
DC-Micromotors

## Series MCDC 3003 S/C

		MCDC 3003 S/C	
Power supply	U <sub>B</sub>	12 ... 30	V DC
PWM switching frequency	f <sub>PWM</sub>	78,12	kHz
Efficiency	η	95	%
Max. continuous output current <sup>1)</sup>	I <sub>dauer</sub>	3	A
Max. peak output current	I <sub>max</sub>	10	A
Total standby current	I <sub>el</sub>	0,06	A
Speed range		5 ... 30 000	rpm
Scanning rate	N	100	μs
External encoder resolution		≤ 65 535	inc./rev.
Input/output (partially free configurable)		5	
Program memory:			
– memory size		3,3	kWord
– Number of instructions		ca. 1 000	instructions
Operating temperature range		0 ... + 70	°C
Storage temperature		– 25... + 85	°C
Housing material		without housing	
Weight		18	g

<sup>1)</sup> at 22°C ambient temperature

### Connection information

<b>Connection communication:</b>			
Interface		RS232 / CAN	
Communication profile		Faulhaber - ASCII / CAN	
Max. transfer speed rate RS232		115 200	baud
Max. transfer speed rate CAN		1	Mbit/s
<b>Connection "AGND":</b>			
– analog ground		analog GND	
– digital input	external encoder	channel B	
	R <sub>in</sub>	10	kΩ
	f	≤ 400	kHz
<b>Connection "Fault":</b>			
– digital input	R <sub>in</sub>	100	kΩ
– digital output (open collector)	U	≤ U <sub>B</sub>	V
	I	≤ 30	mA
	clear	switched to GND	
	set	high-impedance	
fault output	no error	switched to GND	
	error	high-impedance	
<b>Connection "AnIn":</b>			
– analog input	set speed value	U <sub>In</sub>	"AGND" as GND
		± 10	V
– digital input	PWM set speed value	f	100 ... 2 000
		T	50% ± 0 rpm
	external encoder		channel A
		f	≤ 400
	step frequency input	f	≤ 400
		R <sub>in</sub>	5
			kΩ
			kHz
			kHz
			kΩ
<b>Connection "+24V":</b>			
	U <sub>B</sub>	12 ... 30	V DC
<b>Connection "GND":</b>			
		ground	
<b>Connection "3. In":</b>			
– digital input	R <sub>in</sub>	22	kΩ
– electronic supply voltage <sup>2)</sup>	U <sub>B</sub>	12 ... 30	V DC
<b>Connection "4. In":</b>			
– digital input	R <sub>in</sub>	22	kΩ
<b>Connection "5. In":</b>			
– digital input	R <sub>in</sub>	22	kΩ

<sup>2)</sup> Separate supply is optionally available (Option no. 2993).

### Connection information

Connection "Mot -", "Mot +":				
Motor connection	Mot - Mot +		Motor - Motor +	
PWM switching frequency		$U_{Out}$ $f_{PWM}$	0 ... $U_B$ 78,12	V kHz
Connection "Ch A", "Ch B":				
Encoder input	CH A CH B		encoder channel A encoder channel B	
Integrated pullup resistance + 5V		R f	2,2 $\leq 400$	k $\Omega$ kHz
Connection "SGND":				
Signal GND			signal ground	
Connection "+5V":				
Output voltage for external use <sup>1)</sup>		$U_{Out}$	5	V DC
Load current		$I_{Out}$	$\leq 60$	mA

<sup>1)</sup> E.g. encoder

### Digital inputs general information

- PLC, default	high	12,5 ... $U_B$	V
	low	0 ... 7	V
- TTL	high	3,5 ... $U_B$	V
	low	0 ... 0,5	V

The signal level (PLC or TTL) of the digital inputs can be set over the interface (see instruction manual).

### Dimensional drawing and connection information MCDC 3003 S/C

Scale reduced

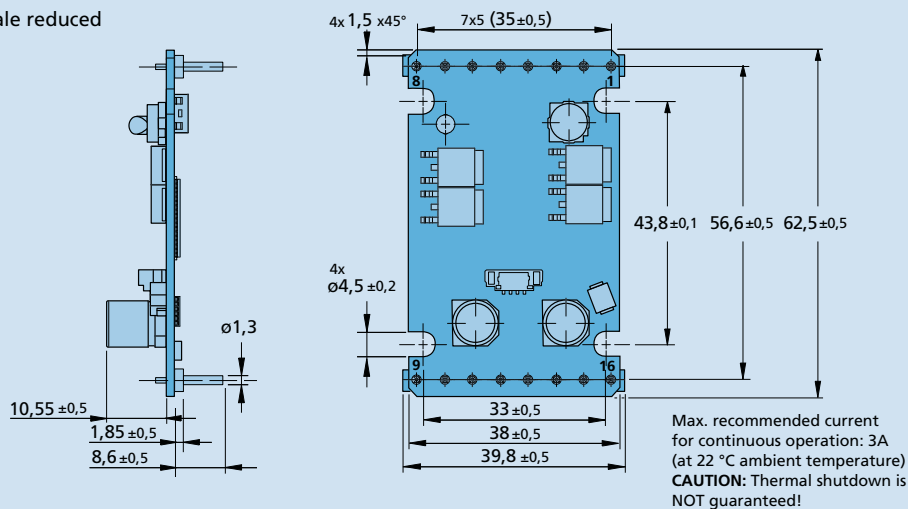

#### Connection

Pin	Function
1	5. In
2	4. In
3	Ch A
4	Ch B
5	+ 5V
6	SGND
7	Mot +
8	Mot -
9	TxD / CAN_H
10	RxD / CAN_L
11	AGND
12	Fault
13	AnIn
14	+ 24V
15	GND
16	3. In

## MC Function / RS232

### General description

FAULHABER Motion Controllers are available as external electronic controls to be used in combination with DC-Micromotors, Brushless DC-Servomotors and Linear DC-Servomotors or, if already integrated, with Brushless DC-Servomotors in the form of motion control systems. Motion control is thus possible for the majority of motors from a diameter of 6 mm upward. The integrated systems reduce the amount of space required. At the same time, their wiring requirements are minimal, which helps to simplify installation.

### Operating modes

- **Speed control**  
PI speed control, even for demanding synchronization requirements
- **Positioning**  
For moving to defined positions with a high level of resolution. With a PD Controller, the dynamic response can be adjusted to suit the application. Reference and limit switches are evaluated by means of various homing modes.
- **Speed profiles**  
Acceleration ramps, deceleration ramps and maximum velocity can also be defined for each section. As a result, even complex profiles can be implemented quickly and effectively.
- **Current control**  
Protects the drive by limiting the motor current to the set peak current. The current is limited to the continuous current by the integrated I<sup>2</sup>t monitoring if required.
- **Protective functions**
  - Protection against ESD
  - Overload protection for the electronic circuitry and the motor
  - Self-protection against overheating
  - Overvoltage protection in generator mode
- **Extended operating modes**
  - Stepper motor mode
  - Gearing mode
  - Position control to analog set point
  - Operation as servo amplifier in voltage adjuster mode
  - Torque/force controller using variable set current input

### Interfaces - Discrete I/O

- **Setpoint input**  
Depending on the operating mode, setpoints can be input via the serial port, via an analog voltage value, a PWM signal or a quadrature signal.
- **Error output (Open Collector)**  
This can also be used as a digital input for the evaluation of reference switches or for specifying direction of rotation.
- **RS232 interface**  
For connection to a PC with a transmission rate of up to 115 kbaud. The information can be stored in the integrated memory (FLASH).

The interface also offers the option of querying online operating data and values. The RS232 interface also allows the operation of several networked drives on one control.

### Sensor interfaces (position and speed sensors, depending on motor type)

- **Analog Hall signals**  
Three analog Hall signals, offset by 120°, for motor position and speed in the case of Brushless DC-Motors and Linear DC-Servomotors
- **Incremental encoders**  
Incremental encoders for motor position and speed in the case of DC-Micromotors and as additional sensors for Brushless DC-Motors
- **Absolute encoders**  
Serial SSI port for motor position and speed matching Brushless DC-Servomotors with an AES Encoder

### RS232 Programming / Configuration

An extensive ASCII command set is available for programming and operation. This can be preset from the PC, e.g. via any Windows terminal program or via any other control computer.

In addition, even complex processes can be created from these commands and stored in the drive. Once programmed as a stepper motor, electronic gear or as a speed or position controller via the analogue input, the drive can be operated independently of the RS232 interface.

"Faulhaber Motion Manager" software is available for Windows operating systems. It considerably simplifies operation and configuration and also enables graphic online analysis of the operating data.

### Options

Separate supply of power to the motor and electronic actuator is optional (important for safety-relevant applications), in which case no third input is required. Depending on the controller, additional programming adaptors and connection aids are available. The modes and parameters can be specially preconfigured on request

### Notes

Motion Controllers and Motion Control Systems are accompanied by a **device manual** for installation and putting into operation. A communication and function manual and the "**Faulhaber Motion Manager**" software are available on request and on the Internet at [www.faulhaber.com](http://www.faulhaber.com).

### Connection diagram

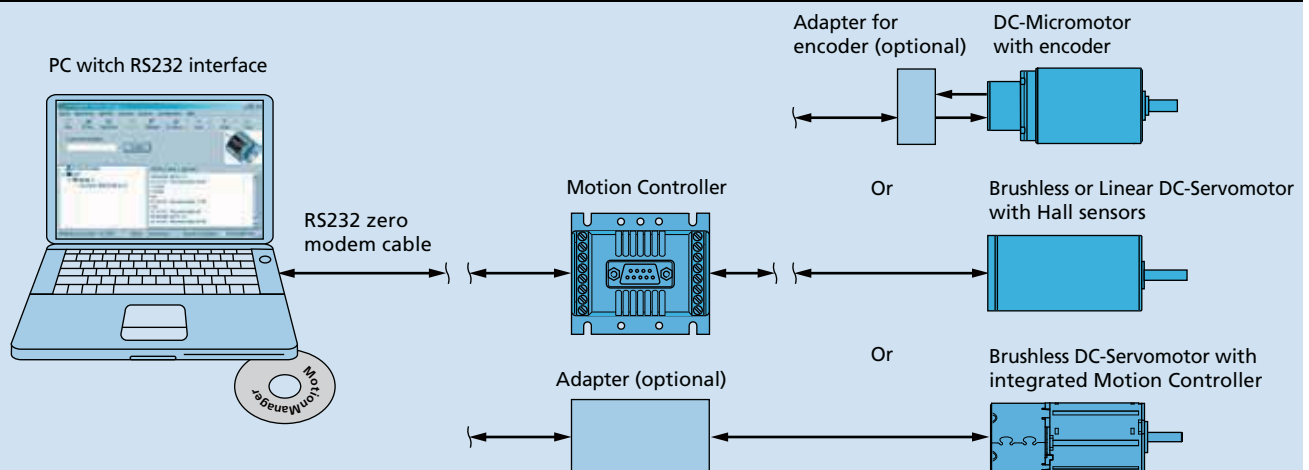

### Position control DC-Micromotor with encoder

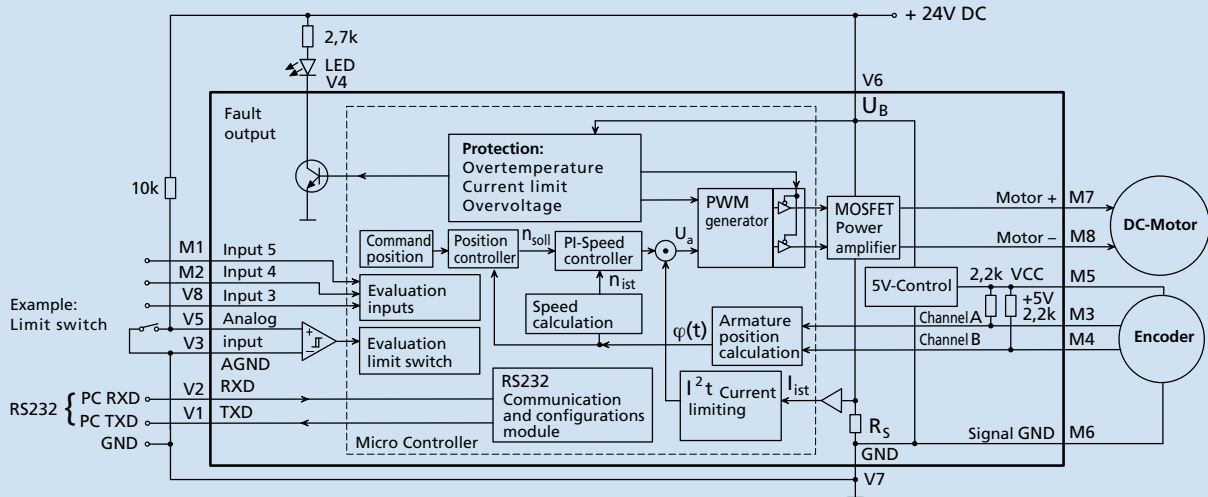

### Position control Brushless DC-Servomotor with Hall sensors

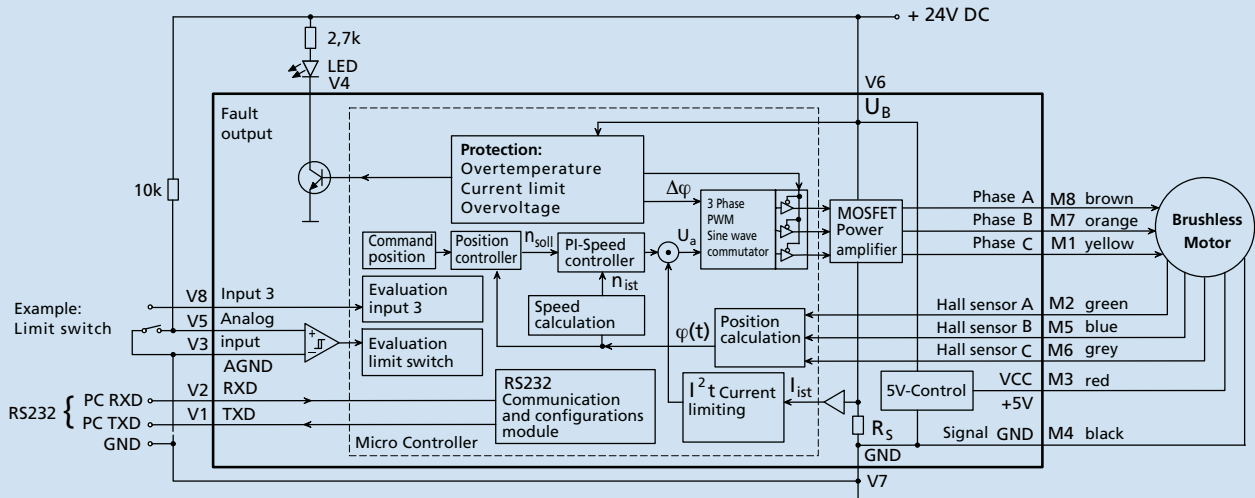

### Position control Brushless DC-Servomotor with integrated Motion Controller

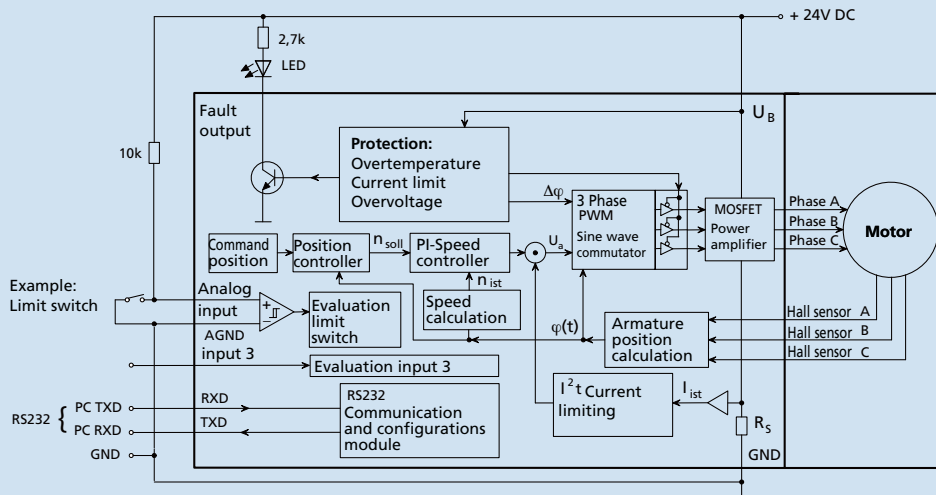

## MC Function / CAN

### General description

FAULHABER Motion Controllers are available as external electronic controls to be used in combination with DC-Micromotors, Brushless DC-Servomotors and Linear DC-Servomotors or, if already integrated, with Brushless DC-Servomotors in the form of motion control systems. Motion control is thus possible for the majority of motors from a diameter of 6 mm upward. The integrated systems reduce the amount of space required. At the same time, their wiring requirements are minimal, which helps to simplify installation.

### Operating modes

- **Speed control**  
PI speed control, even for demanding synchronization requirements
- **Positioning**  
For moving to defined positions with a high level of resolution. With a PD Controller, the dynamic response can be adjusted to suit the application. Reference and limit switches are evaluated by means of various homing modes.
- **Speed profiles**  
Acceleration ramps, deceleration ramps and maximum velocity can also be defined for each section. As a result, even complex profiles can be implemented quickly and effectively.
- **Current control**  
Protects the drive by limiting the motor current to the set peak current. The current is limited to the continuous current by the integrated I<sup>2</sup>t monitoring if required.
- **Protective functions**
  - Protection against ESD
  - Overload protection for the electronic circuitry and the motor
  - Self-protection against overheating
  - Overvoltage protection in generator mode
- **Extended operating modes**
  - Stepper motor mode
  - Gearing mode
  - Position control to analog set point
  - Operation as servo amplifier in voltage adjuster mode
  - Torque/force controller using variable set current input

### Interfaces - Discrete I/O

- **Setpoint input**  
Depending on the operating mode, setpoints can be input via the serial port, via an analog voltage value, a PWM signal or a quadrature signal.
- **Error output (Open Collector)**  
This can also be used as a digital input for the evaluation of reference switches or for specifying direction of rotation.
- **CANopen interface**  
For integration into a CAN network with transfer rates of up to 1 Mbit/s. Via the CAN interface a number of drives can be networked and operated on a higher-level control.

### Sensor interfaces (position and speed sensors, depending on motor type)

- **Analog Hall signals**  
Three analog Hall signals, offset by 120°, for motor position and speed in the case of Brushless DC-Motors and Linear DC-Servomotors
- **Incremental encoders**  
Incremental encoders for motor position and speed in the case of DC-Micromotors and as additional sensors for Brushless DC-Motors
- **Absolute encoders**  
Serial SSI port for motor position and speed matching Brushless DC-Servomotors with an AES Encoder

### CAN Programming / Configuration

FAULHABER Motion Controllers support the CANopen communication profile under DS301 V4.02 in accordance with the CiA specification for slave devices with the following services:

- 1 Server SDO
- 3 transmit PDOs, 3 receive PDOs
- Static PDO mapping
- NMT with node guarding
- Emergency Object

The transfer rate and node no. are set via the network in accordance with the LSS protocol conforming to DSP305 V1.11, and automatic baud rate detection is also implemented. In addition, all the functions and parameters of the drive unit can be easily activated via a special FAULHABER PDO channel.

As regards the CiA device profile for Motion Controllers (CiA 402), the following are supported:

- Profile Position Mode and Position Control Function
- Homing Mode
- Profile Velocity Mode

Also, for each Faulhaber command there is an appropriate CAN frame available on the PDO channel, with which the CAN unit can be operated in the same way as the serial variant and the extended operating modes can be supported.

"Faulhaber Motion Manager" software is available for Windows operating systems. It considerably simplifies operation and configuration and also enables graphic online analysis of the operating data.

### Options

Separate supply of power to the motor and electronic actuator is optional (important for safety-relevant applications), in which case no third input is required. Depending on the controller, additional programming adaptors and connection aids are available. The modes and parameters can be specially preconfigured on request

### Notes

Motion Controllers and Motion Control Systems are accompanied by a **device manual** for installation and putting into operation.

A communication and function manual and the "**Faulhaber Motion Manager**" software are available on request and on the Internet at [www.faulhaber.com](http://www.faulhaber.com).

### Connection diagram

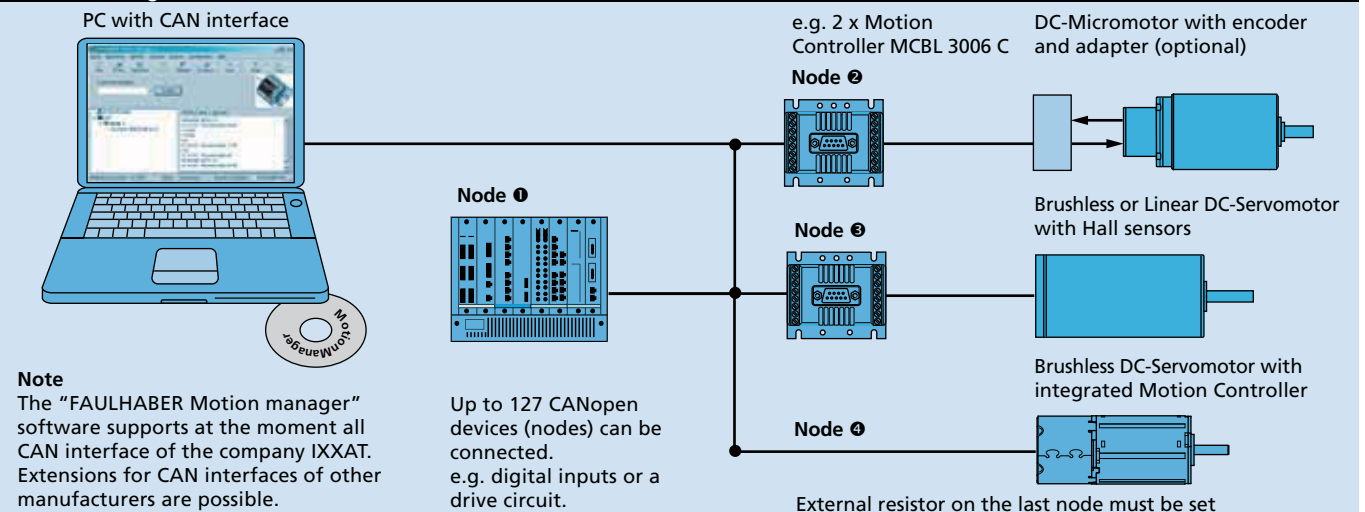

**Note**  
The "FAULHABER Motion manager" software supports at the moment all CAN interface of the company IXXAT. Extensions for CAN interfaces of other manufacturers are possible.

Up to 127 CANopen devices (nodes) can be connected.  
e.g. digital inputs or a drive circuit.

External resistor on the last node must be set

### Position control DC-Micromotor with encoder

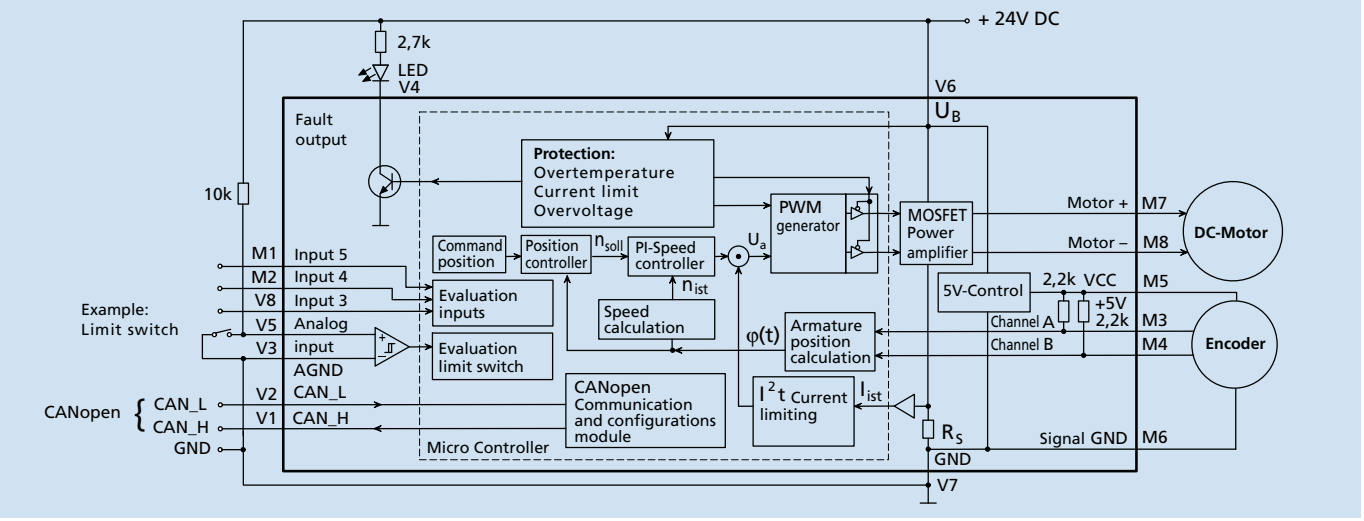

### Position control Brushless DC-Servomotor with Hall sensors

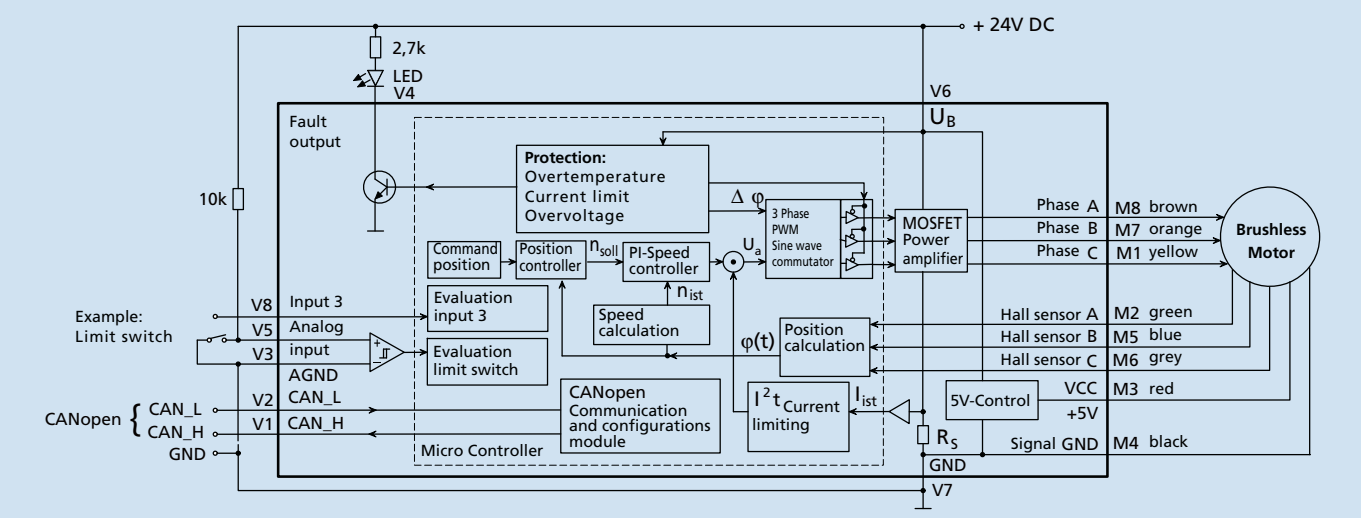

### Position control Brushless DC-Servomotor with integrated Motion Controller

