

Motion Controller

4-Quadrant PWM with CAN interface

For combination with:
DC-Micromotors

Series MCDC 3003/06 C

		MCDC 3003 C	MCDC 3006 C	
Power supply	U_B	12 ... 30	12 ... 30	V DC
PWM switching frequency	f_{PWM}	78,12	78,12	kHz
Efficiency	η	95	95	%
Max. continuous output current ¹⁾		3	6	A
Max. peak output current	I_{max}	10	10	A
Total standby current	I_{el}	0,06	0,06	A
Speed range		5 ... 30 000	5 ... 30 000	rpm
Scanning rate	N	100	100	μ s
External encoder resolution		$\leq 65\,535$	$\leq 65\,535$	inc./rev.
Input/output (partially free configurable)		5	5	
Operating temperature range		0 ... + 70	0 ... + 70	$^{\circ}$ C
Storage temperature		- 25 ... + 85	- 25 ... + 85	$^{\circ}$ C
Housing material		without housing	aluminium, black anodized	
Weight		18	160	g

¹⁾ at 22 $^{\circ}$ C ambient temperature

Connection information				
Connection "CANH", "CANL":			CAN-High / CAN-Low	
Interface			CAN	
Communication profile			CANopen	
Max. transfer speed rate			1	Mbit/s
Connection "AGND":				
- analog ground			analog GND	
- digital input external encoder			channel B	
	R_{in}	10		k Ω
	f	≤ 400		kHz
Connection "Fault":				
- digital input		R_{in}	100	k Ω
- digital output (open collector)		U	$\leq U_B$	V
	I	≤ 30		mA
	clear		switched to GND	
	set		high-impedance	
	no error		switched to GND	
	error		high-impedance	
Connection "AnIn":			"AGND" as GND	
- analog input set speed value		U_{in}	± 10	V
- digital input PWM set speed value		f	100 ... 2 000	Hz
	T		50% \pm 0 rpm	
	external encoder		channel A	
	f	≤ 400		kHz
	f	≤ 400		kHz
	R_{in}	5		k Ω
Connection "+24V":		U_B	12 ... 30	V DC
Connection "GND":			ground	
Connection "3. In":				
- digital input		R_{in}	22	k Ω
- electronic supply voltage ²⁾		U_B	12 ... 30	V DC
Connection "4. In":				
- digital input		R_{in}	22	k Ω
Connection "5. In":				
- digital input		R_{in}	22	k Ω

²⁾ Optional on request

Connection information

Connection "Mot -", "Mot +":			
Motor connection	Mot - Mot +		Motor - Motor + 0 ... U_B
PWM switching frequency		U_{Out} f_{PWM}	78,12 kHz
Connection "Ch A", "Ch B":			
Encoder input	CH A CH B		encoder channel A encoder channel B
Integrated pullup resistance + 5V		R f	2,2 ≤ 400
			k Ω kHz
Connection "SGND":			
Signal GND			signal ground
Connection "+5V":			
Output voltage for external use ¹⁾		U_{Out}	5 V DC
Load current		I_{out}	≤ 60 mA

¹⁾ E.g. encoder

D-SUB-connector information

Connection D-SUB-connector:			
Pin 2	CAN_L		CAN-Low
Pin 3	GND		Ground
Pin 7	CAN_H		CAN-High

Digital inputs general information

- PLC, default	high	12,5 ... U_B	V
	low	0 ... 7	V
- TTL	high	3,5 ... U_B	V
	low	0 ... 0,5	V

The signal level (PLC or TTL) of the digital inputs can be set over the interface (see instruction manual).

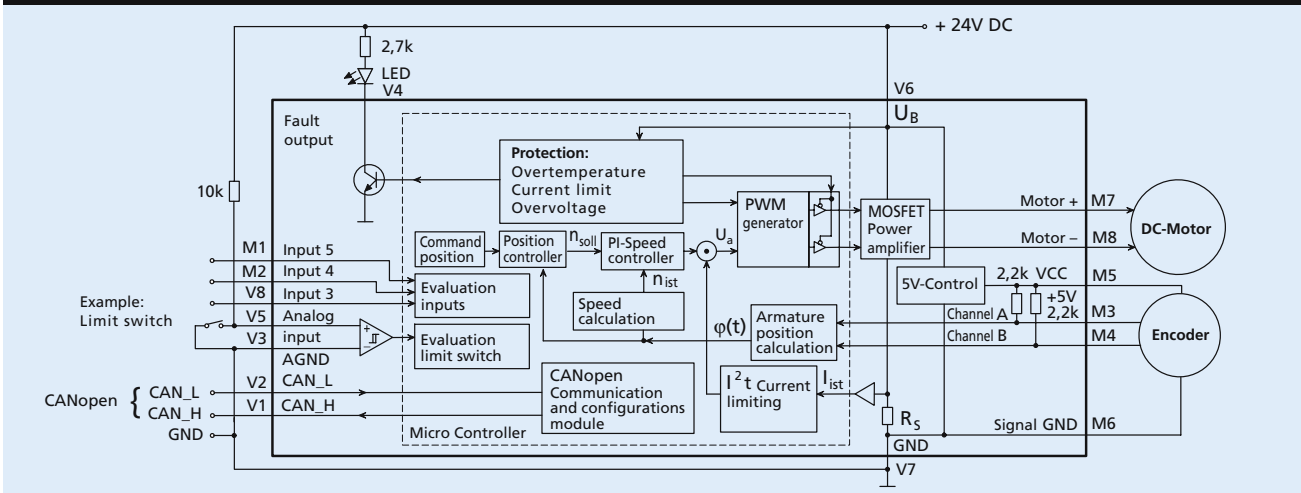
Position control

Motion Controller

General description

The MCDC 3003/06 C is the perfect controller for the entire range of FAULHABER DC-Micromotors. In conjunction with the proven IE2-512 encoders, they are capable of achieving a positioning resolution of 0.18°. A special ballast circuit protects the electronics from over-voltage during braking in generator mode.

Maximum performance:

- **PI speed controller** with superior performance specifications in respect of synchronous operation and minimal torque fluctuations.
- **Speed profiles** such as e.g. ramp, triangular or trapezoidal movements. More complex profiles can also be implemented.
- **Positioning** with high resolution, including **limit switches and zero referencing**.
- **Operation as torque controller** through current regulation.
- **Extended operating modes:**
 - Stepper motor mode
 - Gearing mode (electronic gear)
 - Analogue positioning mode (position control with analogue voltage)
 - Voltage regulator mode
 - Analogue target current presetting
 - IxR control

Latest technology in micro format:

- High efficiency
- Power amplifier with very high PWM frequency
- Power MOSFETs with minimal on-resistance
- Unique thermal protection device determines MOSFET silicon temperature
- High-capacity 16 bit signal processor

Versatile communication:

- **Set-point input** for speed presetting. Processes analogue and PWM signals. The input can also be used for a frequency or reference mark signal.
- **Error output** (Open Collector). Can also be programmed as a rotational direction or reference mark input.
- **Additional digital inputs**
- **CANopen interface** for integration into a CAN network with transfer rates up to 1Mbit/s

Programming made easy

The MCDC 3003/06 C supports the CANopen communication profile according to DS301 V4.02 and DSP402 V2.0 in accordance with the CIA specification for slave devices with the following services:

- 1 Server SDO
- 3 Transmit PDOs, 3 Receive PDOs
- Static PDO Mapping
- NMT with Node Guarding
- Emergency Object

The transfer rate and node no. are set via the network in accordance with the LSS protocol according to DSP305 V1.11, and automatic baud rate detection is also implemented. In addition, all functions and parameters of the drive unit can be very easily activated via a special FAULHABER PDO channel. For each FAULHABER command a corresponding CAN message frame is available on the PDO channel, enabling the CAN unit to be operated analogously to the serial variant.

For Windows operating systems the "FAULHABER Motion Manager" software is available. This considerably simplifies operation and configuration and also enables graphic online analysis of the operating data.

Fields of application

The Motion Controller can be used in many different areas. Thanks to the highly flexible connection options, this device is suitable for a diverse range of applications, for example in decentralised systems of automation technology, as well as in pick-and-place machines and machine tools.

Options

- Adapter for IE2 or HEDL encoder
- Separate supply of motor and control electronics is optionally possible (important for safety-relevant applications); in this case the 3rd input is not required.
- Special preconfiguration of modes and parameters is possible on request.
- The "FAULHABER Motion Manager" software is available on request or on the Internet.

Note

A detailed instruction manual for installation and operation are provided with the Motion Manager.

Connection diagram

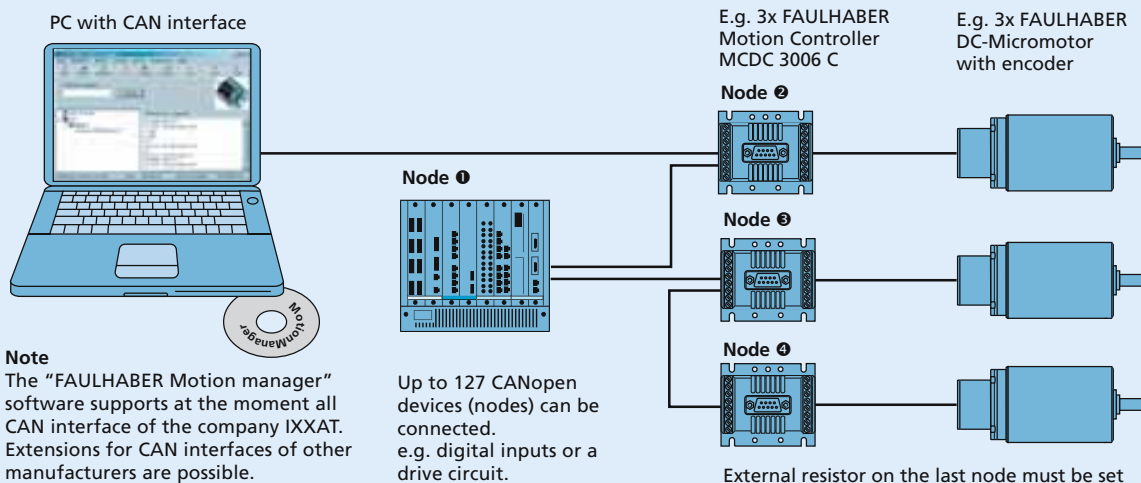

Note

The "FAULHABER Motion manager" software supports at the moment all CAN interface of the company IXXAT. Extensions for CAN interfaces of other manufacturers are possible.

Up to 127 CANopen devices (nodes) can be connected. e.g. digital inputs or a drive circuit.

External resistor on the last node must be set

Dimensional drawing and connection information MCDC 3003 C

Scale reduced

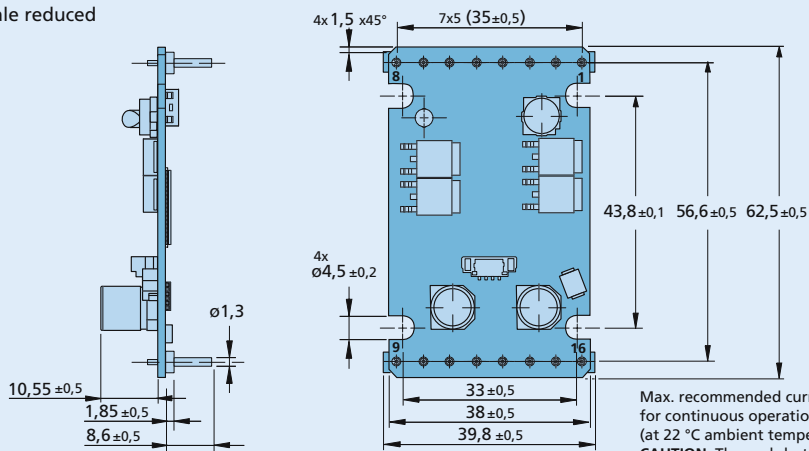

Max. recommended current for continuous operation: 3A (at 22 °C ambient temperature)
CAUTION: Thermal shutdown is NOT guaranteed!

Connection

Pin	Function
1	5. In
2	4. In
3	Ch A
4	Ch B
5	+ 5V
6	SGND
7	Mot +
8	Mot -
9	CAN_H
10	CAN_L
11	AGND
12	Fault
13	AnIn
14	+ 24V
15	GND
16	3. In

Dimensional drawing and connection information MCDC 3006 C

Scale reduced

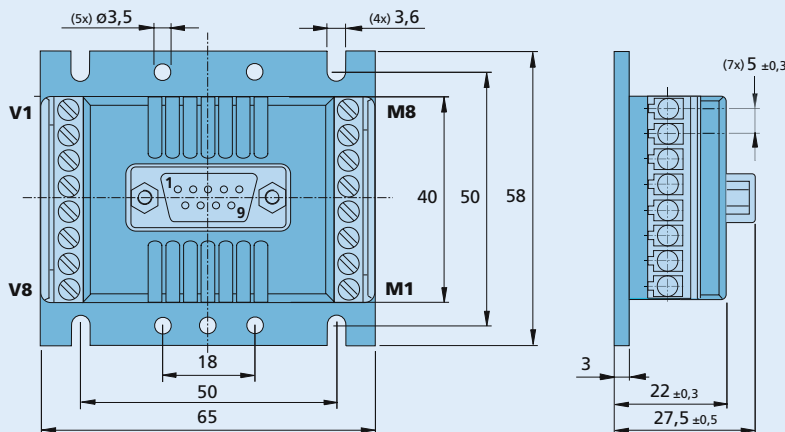

Motor connection

No.	Function
M1	5. In
M2	4. In
M3	Ch A
M4	Ch B
M5	+ 5V
M6	SGND
M7	Mot +
M8	Mot -

Supply connection

No.	Function
V1	CAN_H
V2	CAN_L
V3	AGND
V4	Fault
V5	AnIn
V6	+ 24V
V7	GND
V8	3. In