

Motion Controller

4-Quadrant PWM
with RS232 interface

For combination with:
DC-Micromotors

Series MCDC 3003/06 S

		MCDC 3003 S	MCDC 3006 S	
Power supply	U_B	12 ... 30	12 ... 30	V DC
PWM switching frequency	f_{PWM}	78,12	78,12	kHz
Efficiency	η	95	95	%
Max. continuous output current ¹⁾	I_{dauer}	3	6	A
Max. peak output current	I_{max}	10	10	A
Total standby current	I_{el}	0,06	0,06	A
Speed range		5 ... 30 000	5 ... 30 000	rpm
Scanning rate	N	100	100	μ s
External encoder resolution		\leq 65 535	\leq 65 535	inc./rev.
Input/output (partially free configurable)		5	5	
Program memory:				
– memory size		3,3	3,3	kWord
– Number of instructions		ca. 1 000	ca. 1 000	instructions
Operating temperature range		0 ... + 70	0 ... + 70	°C
Storage temperature		– 25... + 85	– 25 ... + 85	°C
Housing material		without housing	aluminium, black anodized	
Weight		18	160	g

¹⁾ at 22°C ambient temperature

Connection information

Connection "TxD", "RXD":				
Interface		RS232		
Communication profile		Faulhaber - ASCII		
Max. transfer speed rate		115 200		baud
Connection "AGND":				
– analog ground		analog GND		
– digital input	external encoder	channel B		
	R_{in}	10		k Ω
	f	\leq 400		kHz
Connection "Fault":				
– digital input	R_{in}	100	channel B	k Ω
– digital output (open collector)	U	$\leq U_B$		V
	I	\leq 30		mA
	clear	switched to GND		
	set	high-impedance		
	no error	switched to GND		
	error	high-impedance		
	fault output			
Connection "AnIn":				
– analog input	set speed value	U_{in}	"AGND" as GND	
– digital input	PWM set speed value	f	\pm 10	V
		T	100 ... 2 000	Hz
	external encoder		50% \pm 0 rpm	
			channel A	
		f	\leq 400	kHz
	step frequency input	f	\leq 400	kHz
		R_{in}	5	k Ω
Connection "+24V":				
	U_B	12 ... 30		V DC
Connection "GND":				
		ground		
Connection "3. In":				
– digital input	R_{in}	22		k Ω
– electronic supply voltage ²⁾	U_B	12 ... 30		V DC
Connection "4. In":				
– digital input	R_{in}	22		k Ω
Connection "5. In":				
– digital input	R_{in}	22		k Ω

²⁾ Optional on request

Connection information

Connection "Mot -", "Mot +":			
Motor connection	Mot - Mot +		Motor - Motor + 0 ... U _B 78,12
PWM switching frequency		U _{Out} f _{PWM}	V kHz
Connection "Ch A", "Ch B":			
Encoder input	CH A CH B		encoder channel A encoder channel B
Integrated pullup resistance + 5V		R f	2,2 ≤ 400
Connection "SGND":			
Signal GND			signal ground
Connection "+5V":			
Output voltage for external use ¹⁾		U _{Out}	5 V DC
Load current		I _{out}	≤ 60 mA

¹⁾ E.g. encoder

D-SUB-connector information

Connection D-SUB-connector:			
Pin 2	RxD		RS232 / RxD
Pin 3	TxD		RS232 / TxD
Pin 5	GND		Ground

Digital inputs general information

- PLC, default	high	12,5 ... U _B	V
	low	0 ... 7	V
- TTL	high	3,5 ... U _B	V
	low	0 ... 0,5	V

The signal level (PLC or TTL) of the digital inputs can be set over the interface (see instruction manual).

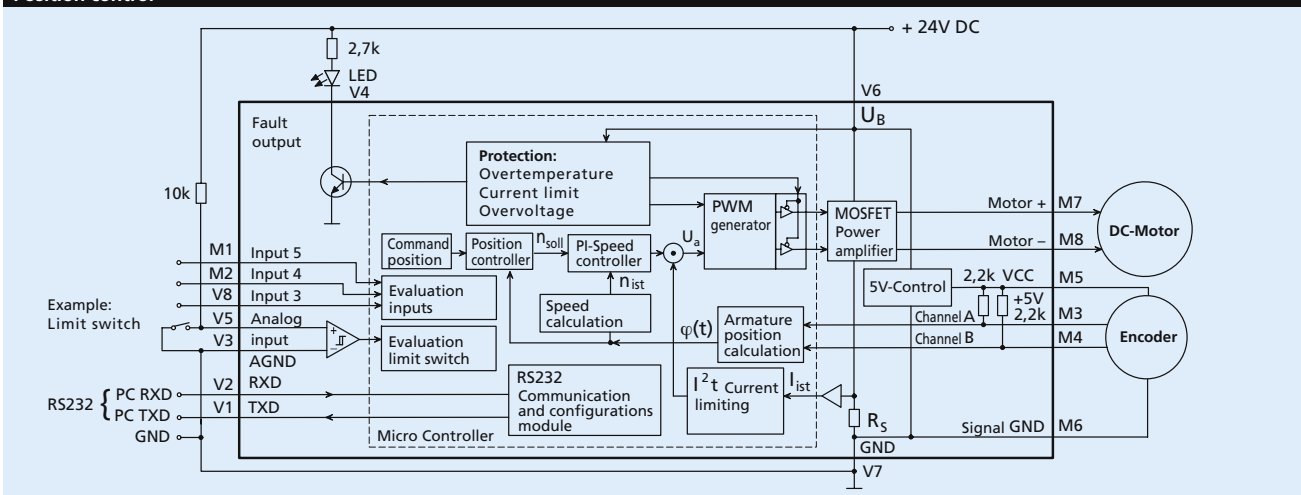
Position control

Motion Controller

General description

The MCDC 3003/06 S is the perfect controller for the entire range of FAULHABER DC-Micromotors. In conjunction with the proven IE2-512 encoders, they are capable of achieving a positioning resolution of 0.18°. A special ballast circuit protects the electronics from over-voltage during braking in generator mode.

Maximum performance:

- **PI speed controller** with superior performance specifications in respect of synchronous operation and minimal torque fluctuations.
- **Speed profiles** such as e.g. ramp, triangular or trapezoidal movements. More complex profiles can also be implemented.
- **Positioning** with high resolution, including **limit switches and zero referencing**.
- **Operation as torque controller** through current regulation.
- **Storage** and execution of motion programs for stand-alone positioning mode or to relieve the HOST computer.
- **Extended** operating modes:
 - Stepper motor mode
 - Gearing mode (electronic gear)
 - Analogue positioning mode (position control with analogue voltage)
 - Voltage regulator mode
 - Analogue target current presetting
 - IxR control

Latest technology in micro format:

- High efficiency
- Power amplifier with very high PWM frequency
- Power MOSFETs with minimal on-resistance
- Unique thermal protection device determines MOSFET silicon temperature
- High-capacity 16 bit signal processor

Versatile communication:

- **Set-point input** for speed presetting. Processes analogue and PWM signals. The input can also be used for a frequency or reference mark signal.
- **Error output** (Open Collector). Can also be programmed as a rotational direction or reference mark input.
- **Additional** digital inputs
- **RS232 interface** for connection to PC or control
- Operation of several drives on a single RS232 interface (Multiplex mode)

Programming made easy

An extensive ASCII command set is available for programming and operation. This can be preset from the PC, e.g. via any terminal program or via any other control computer.

Once programmed as a stepper motor, electronic gear or as speed / position controller via the analogue input, the drive can be operated independently of the RS232 interface.

For Windows operating systems the "FAULHABER Motion Manager" software is available. This considerably simplifies operation and configuration and also enables graphic online analysis of the operating data.

Fields of application

The Motion Controller can be used in many different areas. Thanks to the highly flexible connection options, this device is suitable for a diverse range of applications, for example in decentralised systems of automation technology, as well as in pick-and-place machines and machine tools.

Options

- Adapter for IE2 or HEDL encoder
- Serial null modem cable for RS232 interface
- Separate supply of motor and control electronics is optionally possible (important for safety-relevant applications); in this case the 3rd input is not required.
- Special preconfiguration of modes and parameters is possible on request.
- The "FAULHABER Motion Manager" software is available on request or on the Internet.

Note

A detailed instruction manual for installation and operation are provided with the Motion Manager.

Connection diagram

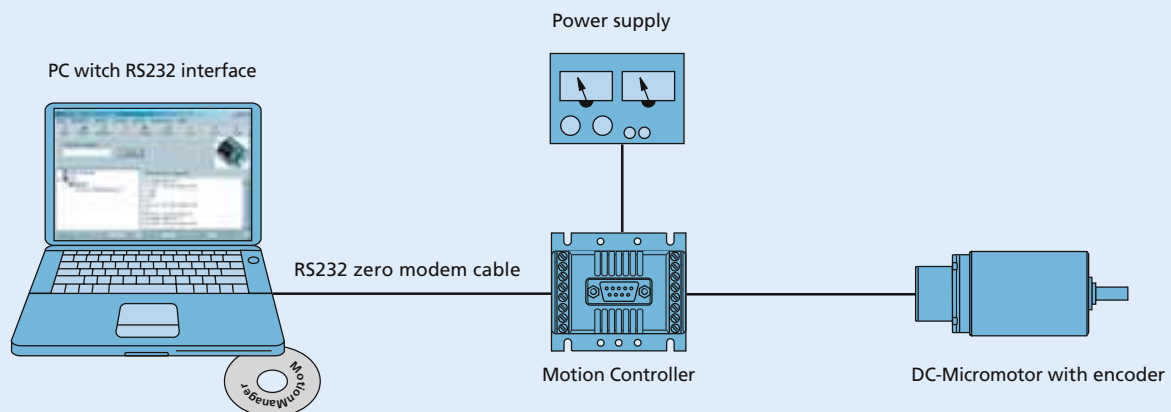

Dimensional drawing and connection information MCDC 3003 S

Scale reduced

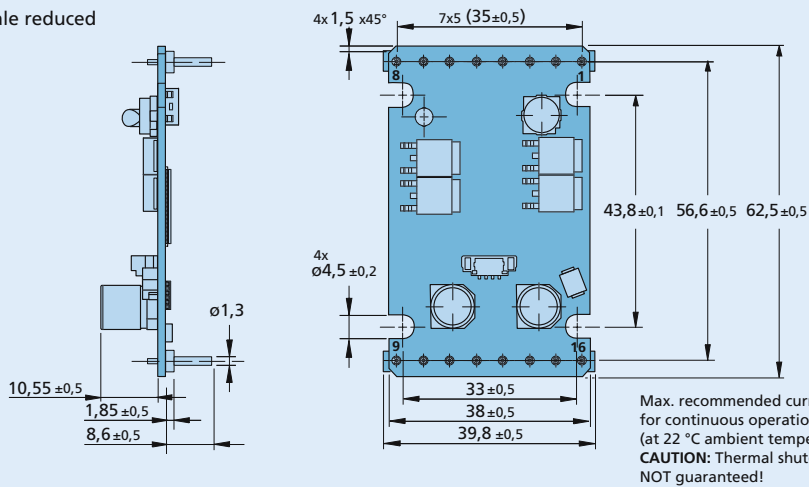

Connection

Pin	Function
1	5. In
2	4. In
3	Ch A
4	Ch B
5	+ 5V
6	SGND
7	Mot +
8	Mot -
9	TxD
10	RxD
11	AGND
12	Fault
13	AnIn
14	+ 24V
15	GND
16	3. In

Dimensional drawing and connection information MCDC 3006 S

Scale reduced

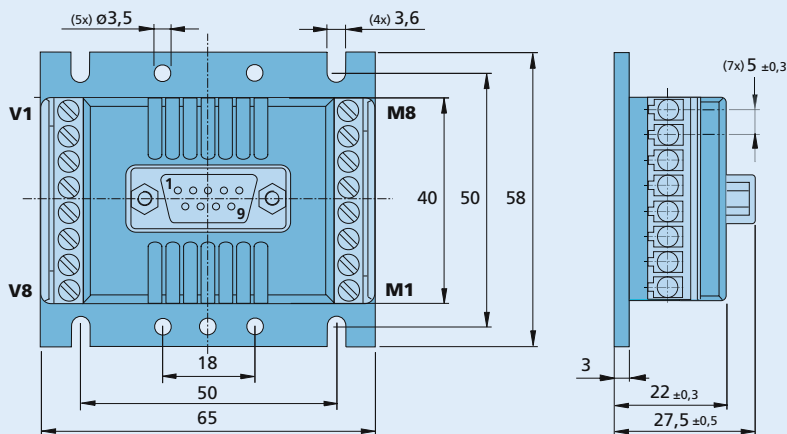

Motor connection

No.	Function
M1	5. In
M2	4. In
M3	Ch A
M4	Ch B
M5	+ 5V
M6	SGND
M7	Mot +
M8	Mot -

Supply connection

No.	Function
V1	TxD
V2	RxD
V3	AGND
V4	Fault
V5	AnIn
V6	+ 24V
V7	GND
V8	3. In