

**NEW**

# Speed Controller

4-Quadrant PWM  
configurable via PC

For combination with:  
DC-Micromotors and  
Brushless DC-Servomotors

## Series SC 5008

		SC 5008 S	
Power supply for electronic	U <sub>p</sub>	6 ... 50	V DC
Power supply for motor	U <sub>mot</sub>	0 ... 50	V DC
Max. continuous output current <sup>1)</sup>	I <sub>dauer</sub>	8	A
Max. peak output current	I <sub>max</sub>	16	A
Total standby current	I <sub>el max</sub>	100	mA
Input/output (partially free configurable)		5	
Tightening torque, terminal strip		0,5 ... 0,6	Nm
Weight		160	g
PWM switching frequency	f <sub>PWM</sub>	96 (24)	kHz
Efficiency	η	95	%
Speed range:			
– BL motors with Hall sensors (digital)		500 ... 100 000	rpm
– BL motors with Hall sensors (analog)		50 ... 60 000	rpm
– DC motors with encoder		100 ... 30 000	rpm
Scanning rate		500	μs
Resolution of encoder with DC motors		≤ 65 535	inc./rev.
Operating temperature range		– 25 ... + 60	°C
Storage temperature		– 25 ... + 85	°C

<sup>1)</sup> at 22°C ambient temperature

### Versions

Speed Controller	Option	Motor Type	Version			Part No.
			Sensor Type	Set speed value specification <sup>1)</sup>	Speed at U <sub>nsoll</sub> = 10 V	
SC 5008 S	3530	BL	Hall sensors (digital) <sup>3)</sup>	0 ... 10 V	20 000 rpm	6500.01480
SC 5008 S	3531	DC	Incremental encoder <sup>2)</sup>	0 ... 10 V	10 000 rpm	6500.01482
SC 5008 S	4289	BL	Hall sensors (analog) <sup>3)</sup>	0 ... 10 V	20 000 rpm	6500.01484

<sup>1)</sup> The velocity range can be configured by software. Versions with PWM and other configurations are available on request.

<sup>2)</sup> preset value is 512 lines

<sup>3)</sup> Factory pre-configured for 2 pole motors. For operation with 4 pole motors the speed controller must be reconfigured with the software "Faulhaber Motion Manager".

### Accessories

		Motor- typ	for SC 5008 S Part No.
Programming adapter	Starterkit		6501.00088
Programming adapter			6501.00096
Motor connector adapter	5 mm » 2,54 mm BX4	BL	6501.00087
Encoder adapter	IE2	DC	6501.00063
	HEDS	DC	6501.00001

**Dimensional drawing and connection information SC 5008 S**

Scale reduced

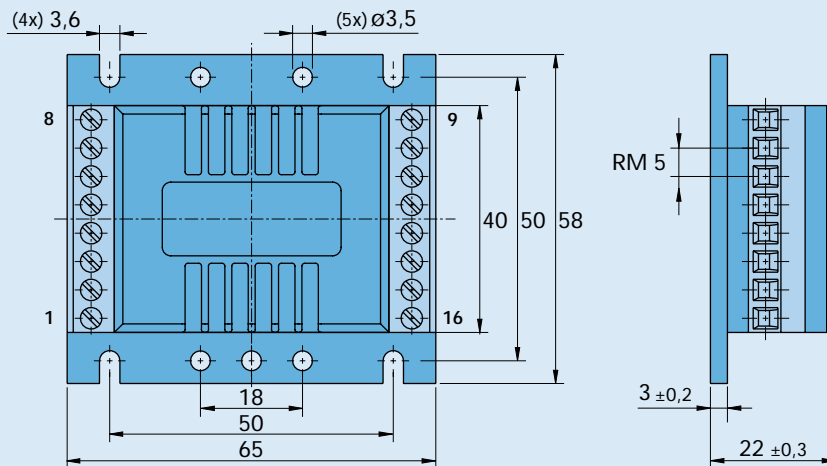

**Connection**

Pin	Function
1	Up
2	U <sub>mot</sub>
3	GND
4	U <sub>sell</sub>
5	DIR
6	FG
7	IO 2
8	IO 1
9	Mot C
10	Mot B
11	Mot A
12	SGND
13	V <sub>cc</sub>
14	Sens C
15	Sens B
16	Sens A

## SC Function

### Speed Controller

#### General description

The Speed Controllers are suitable for both Brushless DC-Servomotors (BL motors) and DC Micromotors (DC motors). With a few exceptions, they cover the entire range of FAULHABER GROUP motors.

#### Main features:

- The Speed Controllers are very flexible. With a programming adapter and the "FAULHABER Motion Manager" software, they can be freely configured by the customer.
- Depending on the configuration, either a BL motor or a DC motor with appropriate sensors for rotation speed measurement can be operated.
- The Speed Controllers are designed as velocity controller. Regulation is effected via a PI regulator.
- Operation without sensors is possible, the revs being determined by evaluating the retroactive generator voltage (EMC).
- Common to all the Speed Controllers is a current limiter that limits the maximum motor current in the case of excessive thermal loading. In the standard configuration, this current limiter is set at the factory to the maximum permitted value for the respective Speed Controller.

#### Standard variants

To allow prompt operability without programming adapter and software, the Speed Controllers are delivered in various standard variants. The variants of each type of controller can be flexibly reconfigured.

#### Configuration by the customer

All Controllers can be configured to one of the operating modes listed below, using a programming adapter and the "FAULHABER Motion Manager" software:

##### ■ BL motors with digital or analog Hall sensors

In the configuration of BL motors with Hall sensors, the motors are operated with controlled revs, the signals of the Hall sensors being used for switching and determining the actual revs.

##### ■ BL motors without Hall sensors (operation without sensors)

In this configuration, no Hall sensors are used. Instead, the retroactive EMC of the motor is used for switching and for controlling the revs.

##### ■ BL Motors with absolute encoder

This mode can only be used with the appropriate hardware. In this configuration the encoder provides rotor position data as an absolute signal. This data is used for both motor commutation and speed control. Due to the very high resolution of the encoder signal, the speed range of the motor can be limited.

##### ■ DC motors with encoders

In the configuration of DC motors with encoders, the motors are operated with controlled revs. An incremental decoder is required as an actual-revs transmitter.

##### ■ DC motors without encoders

In the configuration of DC motors without sensors, the motors are operated with controlled revs, the actual-revs value being registered either via the retroactive generator voltage (EMC), or via IxR compensation, depending on the load. This type of operation must be tuned to the type of motor being used.

In addition to the above, further parameters can be altered using the "FAULHABER Motion Manager" software:

- Regulator parameters
- Output current limitation
- Fixed revs
- Encoder resolution
- Revs set-point specification via analog or PWM signal
- Maximum revs or speed range

#### Areas of use

The low wiring effort and the compact construction of the Speed Controllers allows them to be used in a wide variety of applications. The flexible connection capabilities open up a wide area of use in all fields, for example in distributed automation-technology systems, handling and tooling machines, or pumps.

#### Note

Instruction manuals dealing with installation and commissioning of the Speed Controllers are included in delivery.

Not all speed controllers are suitable for all modes. Detailed information on each operation mode are found in the Data sheets.

### Connection diagram

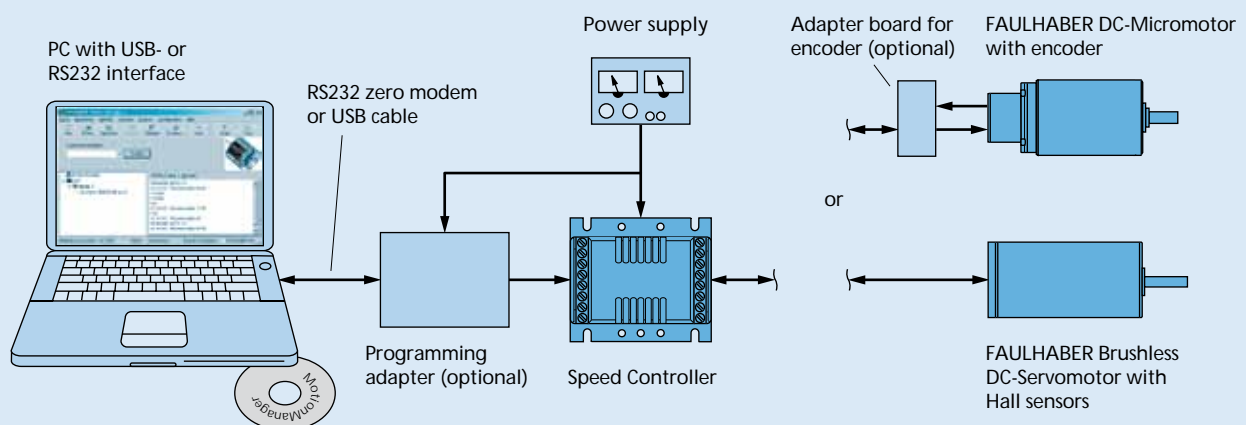

Description of connections (Motor-dependent)	DC motor	BL motor	BL motor with AES
<b>Connection "Mot A", "Mot B", "Mot C":</b>			
- Motor connection			
Mot A	Mot +	Phase A	Phase A
Mot B	Mot -	Phase B	Phase B
Mot C	<i>reserved</i>	Phase C	Phase C
<b>Connection "Sens A", "Sens B", "Sens C":</b>			
- Sensor input			
Sens A	<i>reserved</i>	Hall sensor A	DATA
Sens B	encoder canal A	Hall sensor B	CS
Sens C	encoder canal B	Hall sensor C	CLK
f	≤ 400 kHz		

Connection information (general)			
<b>Connection "Up":</b>	Up		power supply electronic
<b>Connection "U<sub>mot</sub>":</b>	U <sub>mot</sub>		power supply motor coil
<b>Connection "GND":</b>			ground
<b>Connection "U<sub>nsoll</sub>":</b>			
- analog input	set speed value	U <sub>in</sub> = 0 ... 10 V / > 10 V ... max. U <sub>P</sub> <sup>1)</sup>	(standard version)
		U <sub>in</sub> < 0,15 V	motor stops
- digital input	PWM for set speed value	U <sub>in</sub> > 0,3 V (0,5 V) <sup>2)</sup>	motor starts
	duty cycle	500 ... 18 000 Hz	
		d = 0%	motor stopped
		d = 50%	half of maximum speed
		d = 100%	maximum speed
	input resistance	R <sub>in</sub> ≥ 5 kΩ	
	signal level PLC	7,5 ... U <sub>P</sub>	high
		0 ... 2	low
	signal level TTL <sup>3)</sup>	2,8 ... U <sub>P</sub>	high
		0 ... 0,5	low
<b>Connection "DIR":</b>			
- analog input	direction of rotation	to ground or level < 0,5 V	counterclockwise
		level > 3,0 V	clockwise
	input resistance	R <sub>in</sub> ≥ 10 kΩ	
<b>Connection "FG":</b>			
- fault output		max. U <sub>P</sub> / 15 mA	open collector with pull-up resistor <sup>4)</sup>
- frequency output (BL motor only)		switched through to GND	no error
		1, 3, (6) <sup>2)</sup>	lines per revolution
<b>Connection "IO1", "IO2":</b>		n.c.	<i>reserved</i>
<b>Connection "V<sub>cc</sub>":</b>			
	output voltage	5 V DC	for external use
	max. output current for	SC 1801 ... » I <sub>CC</sub> = 25 mA	
		SC 2402 P » I <sub>CC</sub> = 20 mA	
		SC 2804 S » I <sub>CC</sub> = 30 mA	
		SC 5004 P » I <sub>CC</sub> = 100 mA	
		SC 5008 S » I <sub>CC</sub> = 100 mA	
<b>Connection "SGND":</b>			signal ground

<sup>1)</sup> > 10 V for set speed value not defined.

<sup>2)</sup> Data in parentheses apply to BL motors operating without sensors.

<sup>3)</sup> Not available for SC 5004 / SC 5008

<sup>4)</sup> 22 k (SC 1801, SC 2402, SC 2804)

47 k (SC 5004, SC 5008)

An additional external pull-up resistor can be added to improve the rise time.

Caution: I<sub>out</sub> max. 15 mA must not be exceeded.

**Circuit diagram - brushless with Hall sensors (Option 3530)**

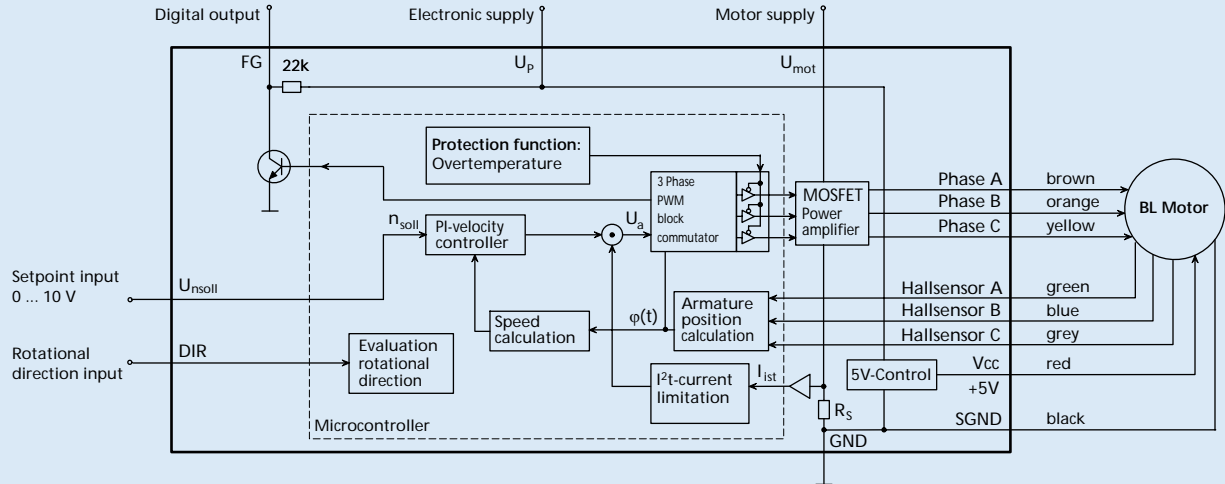

**Connection diagram supply unit**

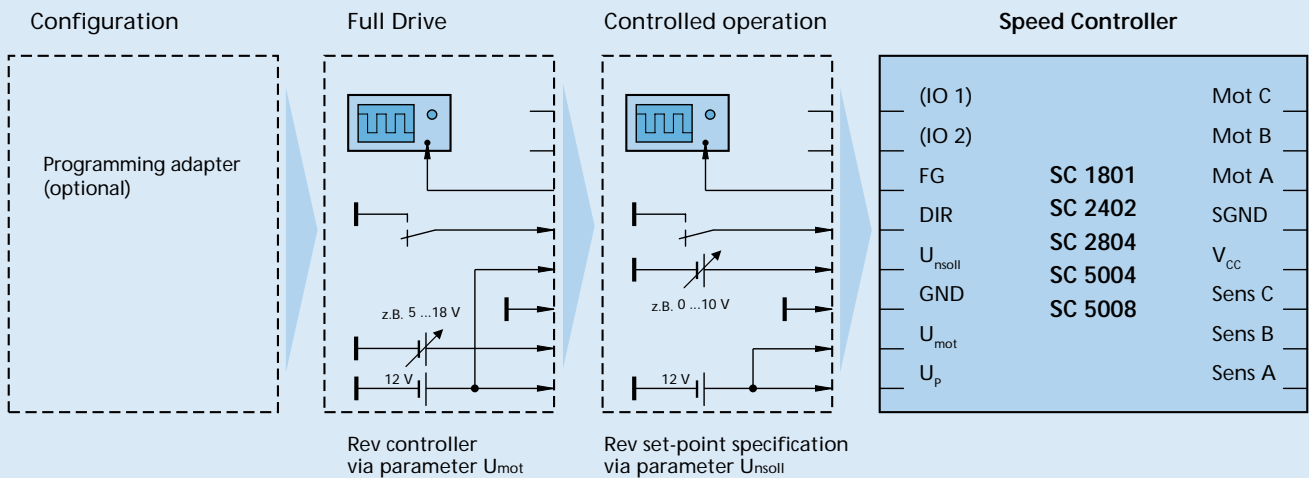

**Connection diagram operation mode DC-Micromotor with encoder**

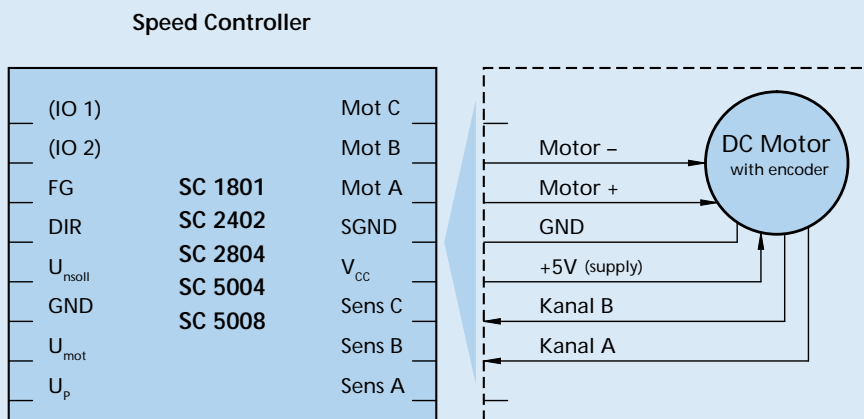

**Connection diagram operation mode BL motor with Hall Sensors**

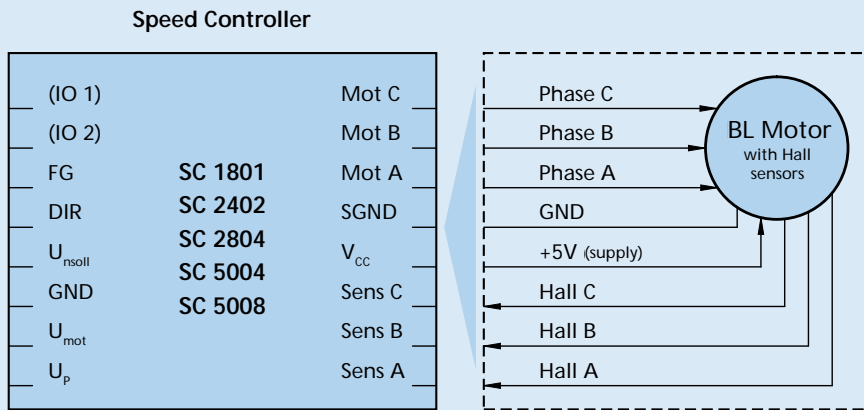

**Connection diagram operation mode BL motor with AES**

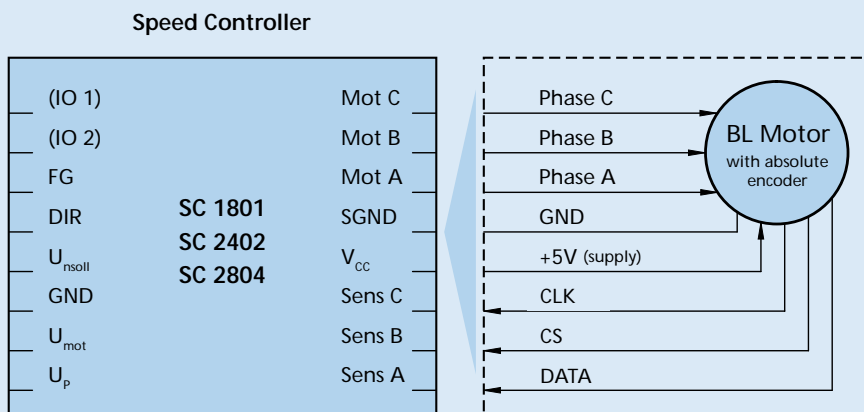

**Connection diagram operation mode DC and BL motor sensorless**

