

NEW

Encoders

Magnetic Encoders

Features:
 32 to 1 024 Lines per revolution
 3 Channels
 Digital output

Series IE3 – 1 024

		IE3 – 32	IE3 – 64	IE3 – 128	IE3 – 256	IE3 – 512	IE3 – 1 024	
Lines per revolution	N	32	64	128	256	512	1 024	
Frequency range ¹⁾ , up to	f	15	30	60	120	240	430	kHz
Signal output, square wave		2+1 index						channels
Supply voltage	U _{DD}	4,5 ... 5,5						V DC
Current consumption, typical ²⁾	I _{DD}	typ. 16, max. 23						mA
Output current, max. ³⁾	I _{OUT}	4						mA
Index Pulse width ⁴⁾	P ₀	90 ± 45						°e
Phase shift, channel A to B ⁴⁾	Φ	90 ± 45						°e
Signal rise/fall time, max. (C _{LOAD} = 50 pF)	tr/tf	0,1 / 0,1						µs
Inertia of encoder magnet	J	0,08						gcm ²
Operating temperature range		– 40 ... + 100						°C

¹⁾ speed (rpm) = f (Hz) x 60/N

²⁾ U_{DD Enc} = 5V: with unloaded outputs

³⁾ U_{DD Enc} = 5V: low logic level < 0,4V, high logic level > 4,5V: CMOS- and TTL compatible

⁴⁾ at 5 000 rpm

Ordering information

Encoder	number of channels	lines per revolution	in combination with:
IE3 – 32	2+1	32	DC-Micromotors series 2342 ... CR, 2642 ... CR, 2657 ... CR, 3242 ... CR, 3257 ... CR, 2237 ... CXR, 2642 ... CXR, 2657 ... CXR
IE3 – 64	2+1	64	
IE3 – 128	2+1	128	
IE3 – 256	2+1	256	
IE3 – 512	2+1	512	
IE3 – 1 024	2+1	1 024	

Features

These incremental shaft encoders in combination with the FAULHABER DC-Micromotors are used for the indication and control of both shaft velocity and direction of rotation as well as for positioning.

A permanent magnet on the shaft creates a moving magnetic field which is captured using a single-chip angular sensor and further processed. At the encoder outputs, two 90° phase-shifted rectangular signals are available with up to 1 024 impulses and an index impulse per motor revolution.

The encoder is available in a variety of different resolutions and is suitable for speed control and positioning applications. The motor and encoder are connected via separate ribbon cables.

Options

- Connector variants (Option no.: 3807)
 AWG 28 / PVC ribbon cable (6-conductors), with connector PicoBlade (pitch 1,25 mm)
- Resolutions from 1 - 127 lines per revolution are available by request.

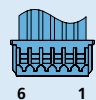

Output signals / Circuit diagram / Connector information

Output signals

with clockwise rotation as seen from the shaft end

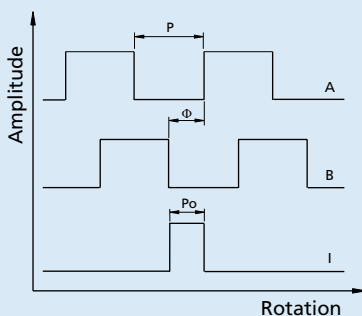

Admissible deviation of phase shift:

$$\Delta\Phi = \left| 90^\circ - \frac{\Phi}{P} * 180^\circ \right| \leq 75^\circ \quad \Delta P_0 = \left| 90^\circ - \frac{P_0}{P} * 180^\circ \right| \leq 75^\circ$$

Output circuit

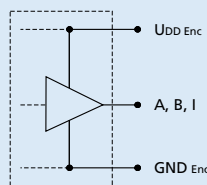

Connection Encoder

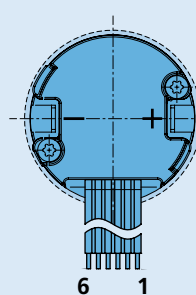

No.	Function
1	n.c.
2	Channel I (Index)
3	GND Enc
4	U _{DD} Enc
5	Channel B
6	Channel A

Caution:

Incorrect lead connection will damage the motor electronics!
 When using the encoder at low temperature it is important to keep the cable unmoved.

DC-Micromotors 23xx ... CR up to 32xx ... CR and 26xx ... CXR with encoder IE3 – 32 ... 1 024

M 1:1 

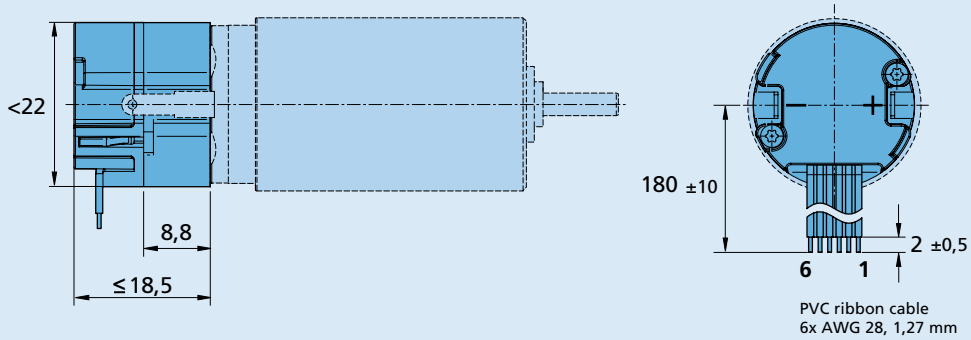

DC-Micromotors 2237...CXR with encoder IE3 – 32 ... 1 024

M 1:1 