

NEW

Encoders

Magnetic Encoders with Line Driver

Features:
 32 to 1 024 Lines per revolution
 3 Channels + complementary outputs
 Digital output

Series IE3 – 1 024 L

		IE3 – 32 L	IE3 – 64 L	IE3 – 128 L	IE3 – 256 L	IE3 – 512 L	IE3 – 1 024 L	
Lines per revolution	N	32	64	128	256	512	1 024	
Frequency range ¹⁾ , up to	f	15	30	60	120	240	430	kHz
Signal output, square wave		2+1 index and complementary outputs						channels
Supply voltage	U _{DD}	4,5 ... 5,5						V DC
Current consumption, typical ²⁾	I _{DD}	typ. 17, max. 25						mA
Index Pulse width ³⁾	P ₀	90 ± 45				90 ± 75		°e
Phase shift, channel A to B ³⁾	Φ	90 ± 45				90 ± 75		°e
Inertia of encoder magnet	J	0,08						gcm ²
Operating temperature range		- 40 ... + 85				- 40 ... + 100		°C

¹⁾ speed (rpm) = f(Hz) x 60/N

²⁾ U_{DD Enc} = 5 V: with unloaded outputs

³⁾ at 5 000 rpm

Notes: The output signals are TIA-422 compatible.

Examples of Line driver Receivers: ST26C32ABD (STM), ST26C32IP16 (EXAR), DS26C32AT (NSC).

Ordering information

Encoder	number of channels	lines per revolution	in combination with:
IE3 – 32 L	2+1	32	DC-Micromotors series 2342 ... CR, 2642 ... CR, 2657 ... CR, 3242 ... CR, 3257 ... CR, 2237 ... CXR, 2642 ... CXR, 2657 ... CXR
IE3 – 64 L	2+1	64	
IE3 – 128 L	2+1	128	
IE3 – 256 L	2+1	256	
IE3 – 512 L	2+1	512	
IE3 – 1 024 L	2+1	1 024	

Features

These incremental encoders have 3 output channels, in combination with the FAULHABER DC-Micromotors are used for the indication and control of both shaft velocity and direction of rotation as well as for positioning.

A permanent magnet on the shaft creates a moving magnetic field which is captured using a single-chip angular sensor and further processed. At the encoder outputs, two 90° phase-shifted rectangular signals are available with up to 1 024 impulses and an index impulse per motor revolution.

The Line Driver version has differential signal outputs (TIA-422). Differential signals reduce ambient interference and are suitable for applications with high ambient interference.

The line driver amplifies the encoder signal which means that long cables can be used without signal degradation.

Differential signal outputs must be decoded by the appropriate receiver module.

The motor and encoder are connected via separate ribbon cables.

Options

- Connector variants (Option no.: 3806) AWG 28 / PVC ribbon cable (10-conductors), with connector DIN-41651 (pitch 2,54 mm)
- Resolutions from 1 - 127 lines per revolution are available by request.

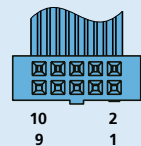

Output signals / Circuit diagram / Connector information

Output signals

with clockwise rotation as seen from the shaft end

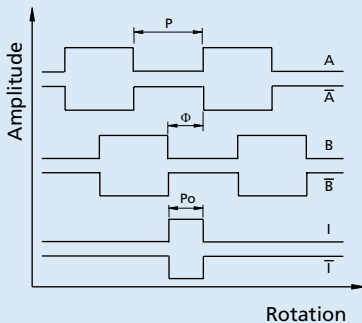

Admissible deviation of phase shift/Index pulse:

$$\Delta\Phi = \left| 90^\circ - \frac{\Phi}{P} * 180^\circ \right| \leq 75^\circ \quad \Delta P_0 = \left| 90^\circ - \frac{P_0}{P} * 180^\circ \right| \leq 75^\circ$$

Output circuit

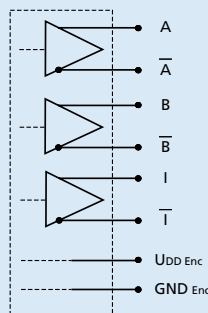

Connection Encoder

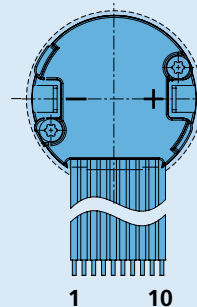

No.	Function
1	n.c.
2	U _{DD} Enc
3	GND Enc
4	n.c.
5	Channel Ā
6	Channel A
7	Channel B̄
8	Channel B
9	Channel Ī (Index)
10	Channel I (Index)

Caution:

Incorrect lead connection will damage the motor electronics!

When using the encoder at low temperature it is important to keep the cable unmoved.

DC-Micromotors 23xx ... CR up to 32xx ... CR and 26xx ... CXR with encoder IE3 – 32 ... 1 024 L

M 1:1

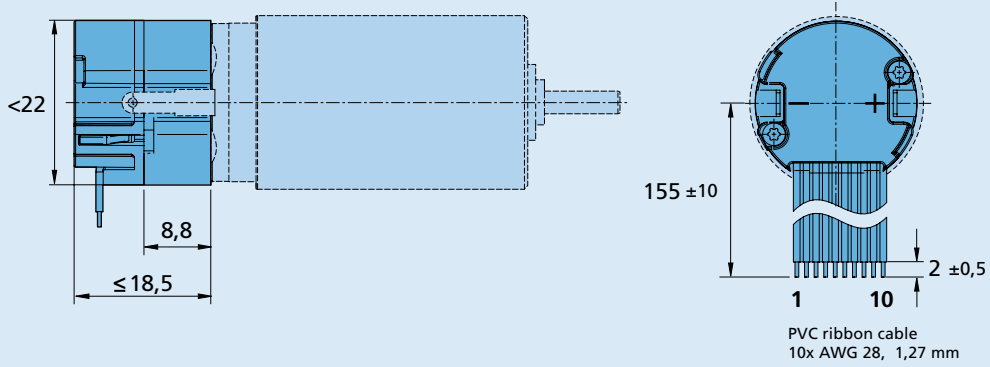

DC-Micromotors 2237 ... CXR with encoder IE3 – 32 ... 1 024 L

M 1:1

