

NEW

Encoders

Optical Encoders

Features:
 50 Lines per revolution
 2 Channels
 Digital output

Series PA2 – 50

		PA2 – 50	
Signal output, square wave		2	channels
Supply voltage (ripple < 100 mV _{p-p})	V _{CC}	2,7 ... 3,3	V DC
Current consumption, typical (V _{CC} = 3 V DC)	I _{CC}	8,5	mA
Current output, per channel	I _{out}	- 1 ... 8	mA
Pulse width	P	180 ± 50	°e
Phase shift, channel A to B	Φ	90 ± 45	°e
Logic state width	S	90 ± 50	°e
Cycle	C	360 ± 36	°e
Signal rise/fall time, typical (C _{LOAD} = 25 pF)	tr/tf	0,3 / 0,1	µs
Frequency range ¹⁾	f	up to 35	kHz
Inertia of code disc	J	0,02	gcm ²
Operating temperature range		- 30 ... + 85	°C

¹⁾ Velocity (rpm) = f (Hz) x 60/N

Ordering information

Encoder	number of channels	lines per revolution	for combination with:
PA2-50	2	50	DC-Micromotors serie 0615 ... S ²⁾ , 0816 ... S Brushless DC-Servomotor serie 0620 ... B ²⁾

Note: Lines per revolution refers to pre-quadrature resolution and equals the cycles per revolution

²⁾ Channel B Leads channel A

Features

These incremental shaft encoders in combination with the DC-Micromotors and Brushless DC-Servomotors are designed for both indication and control of both shaft velocity and direction of rotation as well as for positioning.

An all-in-one emitter and detector chip transmits and receives LED light reflected off a low inertia reflective disc providing two channels with 90° phase shift.

The supply voltage for the encoder and the Micromotor as well as the output signals are interfaced with a flexible printed circuit (FPC).

Details for the DC-Micromotors and Brushless DC-Servomotors and suitable reduction gearheads are on separate catalog pages.

An optional interface board with suitable connector is also available on request.

Output signals / Circuit diagram / Connector information

Output signals

with clockwise rotation as seen from the shaft end

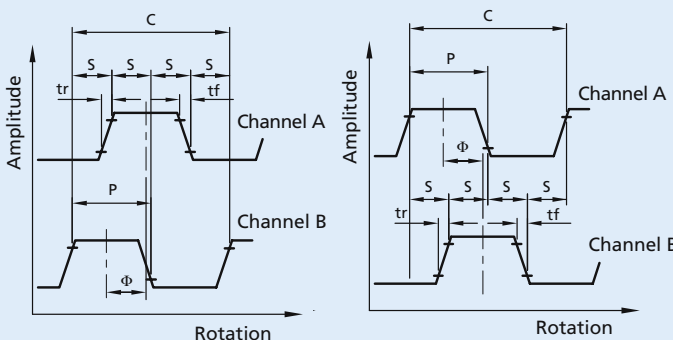

0615 ... S / 0620 ... B

0816 ... S

Output circuit

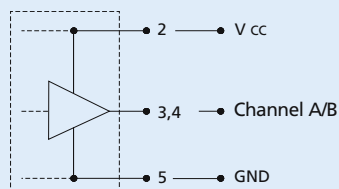

Pin Function

- 1 Motor + *
 - 2 V_{CC}
 - 3 Channel A
 - 4 Channel B
 - 5 GND
 - 6 Motor - *
- * Note: Brushless motors have separate motor leads.

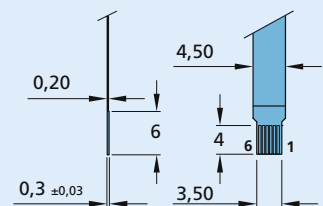

Connector

Molex 52745
 grid 0,5 mm
 FPC / FFC, 6-conductors

DC-Micromotor 0615 N ... S - K1655 with encoder PA2-50

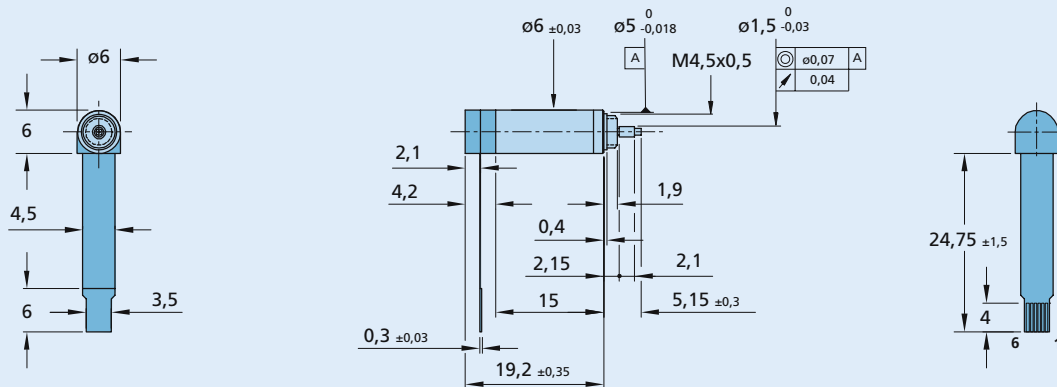

PA2-50 + 0615 N

Brushless DC-Servomotor 0620 K ... S - K1719 with encoder PA2-50

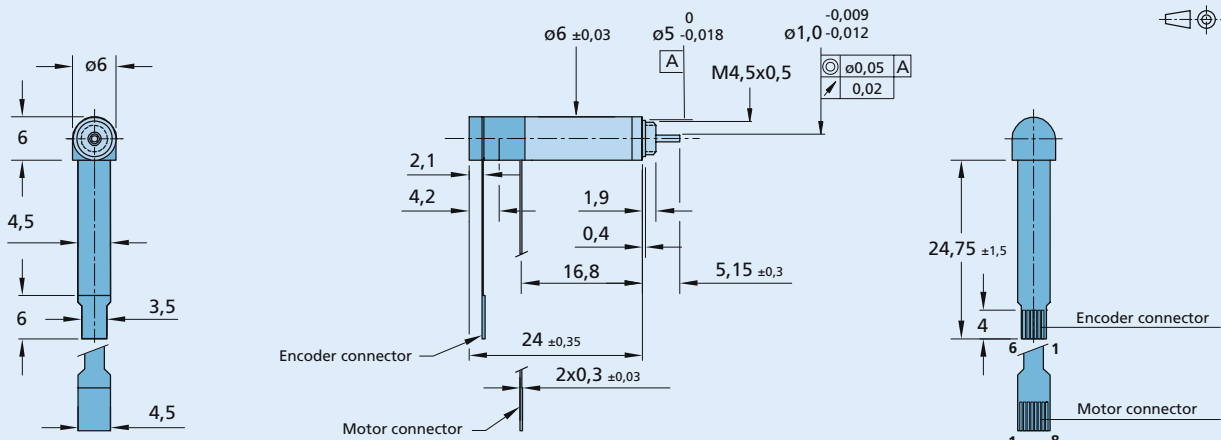

PA2-50 + 0620 K

DC-Micromotor 0816 N ... S - K1752 with encoder PA2-50

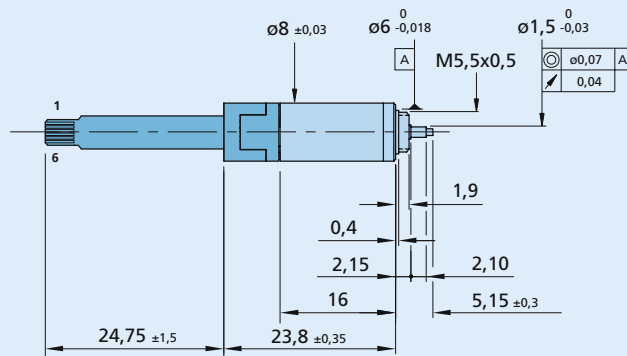

PA2-50 + 0816 N

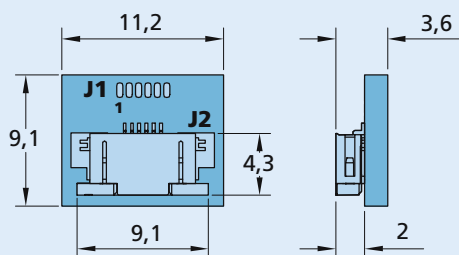
Optional interface board

Interface board PA2-50
Part No.: D100315100

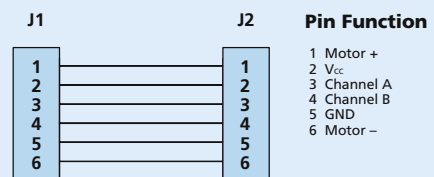

Connector
J1 – Solder Pads
J2 – Molex 52475-0690