

Flat DC-Micromotors

Precious Metal Commutation
with integrated Encoder

2 mNm

For combination with
Drive Electronics:
SC 1801

Series 2607 ... SR IE2-16

	2607 T	006 SR	012 SR	024 SR	IE2-16
Nominal voltage	U _N	6	12	24	Volt
Terminal resistance	R	8	31,2	118,6	Ω
Output power	P _{2 max.}	1,11	1,14	1,22	W
Efficiency	η _{max.}	80	80	80	%
No-load speed	n ₀	6 700	6 900	7 200	rpm
No-load current (with shaft ø 1,5 mm)	I ₀	0,010	0,005	0,0025	A
Stall torque	M _H	6,33	6,31	6,48	mNm
Friction torque	M _R	0,08	0,08	0,08	mNm
Speed constant	k _n	1 130	582	304	rpm/V
Back-EMF constant	k _E	0,884	1,72	3,29	mV/rpm
Torque constant	k _M	8,44	16,4	31,4	mNm/A
Current constant	k _I	0,118	0,061	0,032	A/mNm
Slope of n-M curve	Δn/ΔM	1 060	1 090	1 110	rpm/mNm
Rotor inductance	L	420	1 600	5 800	μH
Mechanical time constant	τ _m	7,5	7,8	7,9	ms
Rotor inertia	J	0,68	0,68	0,68	gcm ²
Angular acceleration	α _{max.}	94	93	95	·10 ³ rad/s ²
Thermal resistance	R _{th 1} / R _{th 2}	10 / 32			K/W
Thermal time constant	τ _{w1} / τ _{w2}	6 / 250			s
Operating temperature range:		0 ... + 70			°C
Shaft bearings		sintered sleeves bearings (standard)	ball bearings (optional)		
Shaft load max.:					
- with shaft diameter		1,5	1,5		mm
- radial at 3000 rpm (3 mm from bearing)		1,2	5		N
- axial at 3000 rpm		0,2	0,5		N
- axial at standstill		20	10		N
Shaft play:					
- radial	≤	0,03	0,015		mm
- axial	≤	0,2	0,2		mm
Housing material		plastic			
Weight		18,6			g
Direction of rotation		clockwise, viewed from the front face			
Recommended values - mathematically independent of each other					
Speed up to	n _{e max.}	5 500	5 500	5 500	rpm
Torque up to	M _{e max.}	2	2	2	mNm
Current up to (thermal limits)	I _{e max.}	0,371	0,187	0,097	A

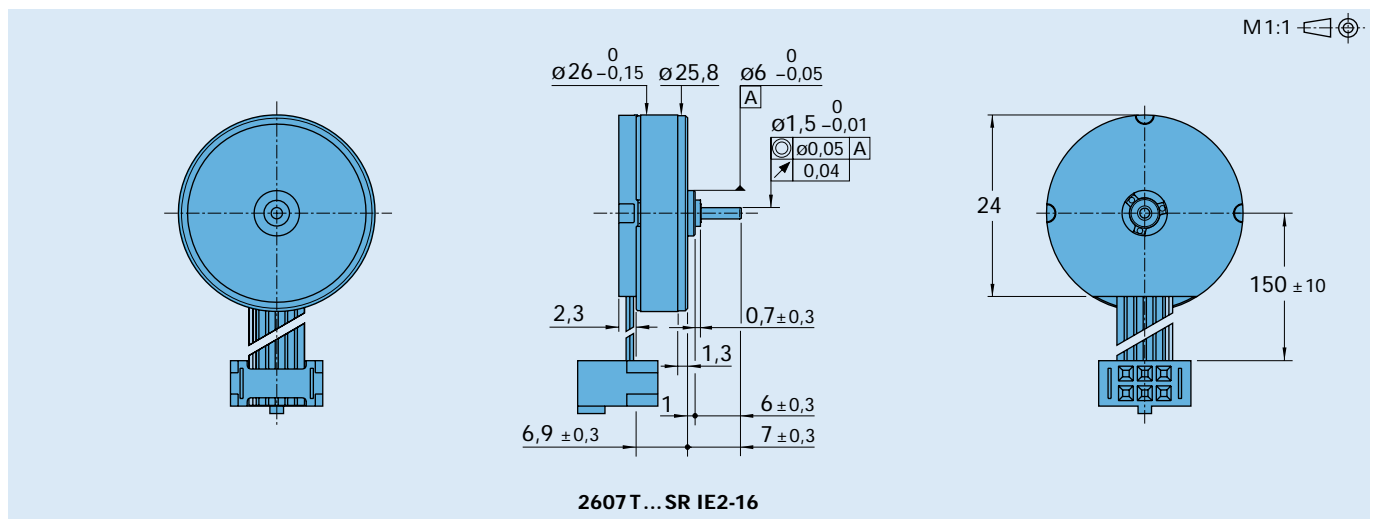

Integrated optical Encoder		IE2-16	
Lines per revolution	N	16	
Signal output, square wave		2	channels
Supply voltage	U _{DD}	3,2 ... 5,5	V DC
Current consumption, typical (U _{DD} = 5 V DC)	I _{DD}	typ. 8, max. 15	mA
Output current, max. allowable (at U _{out} < 1,5V)	I _{OUT}	5	mA
Pulse width ¹⁾	P	180 ± 45	°e
Phase shift, channel A to B ¹⁾	Φ	90 ± 45	°e
Signal rise/fall time, max. (C _{LOAD} = 50 pF)	tr/tf	2,5/0,3	µs
Frequency range ²⁾ , up to	f	4,5	kHz

¹⁾ Ambient temperature 22°C (tested at 1kHz)

²⁾ Velocity (rpm) = f (Hz) x 60/N

Features

In this version, the DC-Micromotors have an optical encoder with two output channels. A code wheel on the shaft is optically captured and further processed. At the encoder outputs, two 90° phase-shifted rectangular signals are available with 16 impulses per motor revolution.

The encoder is suitable for the monitoring and regulation of the speed and direction of rotation and for positioning the drive shaft.

The supply voltage for the encoder and the DC-Micromotor as well as the two channel output signals are interfaced through a ribbon cable with connector.

Full product description

■ Examples:

2607T006SR IE2-16

2607T024SR IE2-16

Output signals / Circuit diagram / Connector information

Output signals

with clockwise rotation as seen from the shaft end

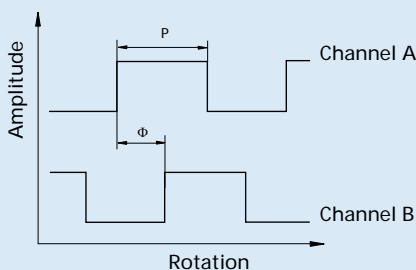

Admissible deviation of phase shift:

$$\Delta\Phi = \left| 90^\circ - \frac{\Phi}{P} * 180^\circ \right| < 45^\circ$$

Output circuit

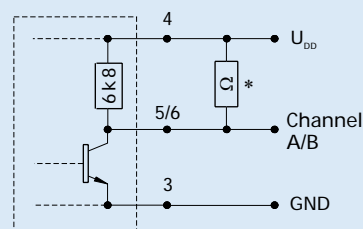

* An additional external pull-up resistor can be added to improve the rise time. Caution: I_{OUT} max. 5 mA must not be exceeded!

