

DC-Gearmotors

Precious Metal Commutation
with integrated Encoder

30 mNm

For combination with
Drive Electronics:
SC 1801

Series 1512 ... SR ... IE2-8

	1512 U	003 SR	006 SR	012 SR	IE2-8
Nominal voltage	U _N	3	6	12	Volt
Terminal resistance	R	11	48,5	130	Ω
Output power	P _{2 max.}	0,19	0,17	0,26	W
No-load speed (motor)	n ₀	13 400	14 300	15 500	rpm
Speed constant	k _n	4 640	2 480	1 340	rpm/V
Back-EMF constant	k _E	0,216	0,403	0,749	mV/rpm
Torque constant	k _M	2,06	3,84	7,15	mNm/A
Current constant	k _I	0,486	0,260	0,140	A/mNm
Slope of n-M curve	Δn/ΔM	24 700	31 400	24 200	rpm/mNm
Rotor inductance	L	175	720	2 100	μH
Rotor inertia	J	0,09	0,09	0,09	gcm ²

Housing material		plastic	
Geartrain material		metal	
Backlash, at no-load	≤	4	°
Bearings on output shaft		plastic / brass bearing	
Shaft load max.:			N
– radial (5 mm from mounting face)	≤	1,4	N
– axial	≤	1	N
Shaft press fit force, max.	≤	15	N
Shaft play:			
– radial (5 mm from mounting face)	≤	0,08	mm
– axial	≤	0,25	mm
Operating temperature range		– 30 ... + 80	°C

Specifications

reduction ratio (rounded)	output speed up to n _{max} rpm	weight with motor g	output torque		direction of rotation (reversible)	efficiency %
			continuous operation M _{max} mNm	intermittent operation M _{max} mNm		
6 : 1	779	6,9	1,4	3	=	81
13 : 1	372	7,0	2,8	5	≠	73
39 : 1	129	7,2	7,0	10	=	60
112 : 1	45	7,4	19,8	30	≠	59
324 : 1	15	7,7	30,0	50	=	53

M 1:1

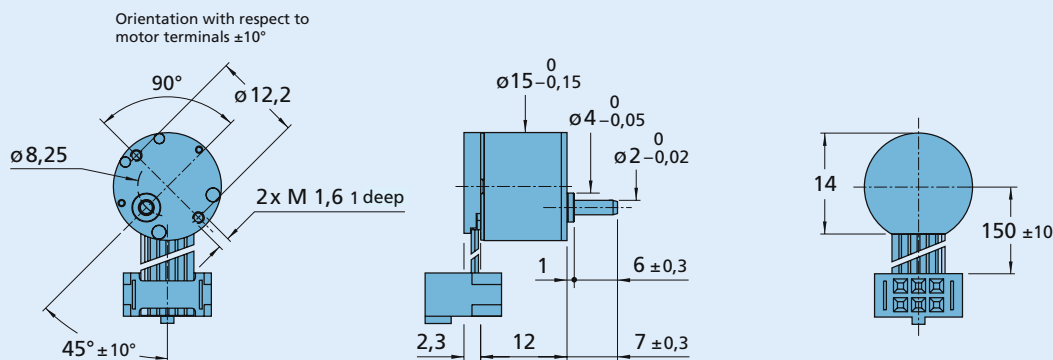

1512U...SR... IE2-8

Integrated optical Encoder		IE2-8	
Lines per revolution	N	8	
Signal output, square wave		2	channels
Supply voltage	U _{DD}	3,2 ... 5,5	V DC
Current consumption, typical (U _{DD} = 5V DC)	I _{DD}	typ. 8, max. 15	mA
Output current, max. allowable (at U _{out} < 1,5V)	I _{OUT}	5	mA
Pulse width ¹⁾	P	180 ± 45	°e
Phase shift, channel A to B ¹⁾	Φ	90 ± 45	°e
Signal rise/fall time, max. (C _{LOAD} = 50 pF)	tr/tf	2,5/0,3	µs
Frequency range ²⁾ , up to	f	4,5	kHz
Operating temperature range		0 ... +70	°C

¹⁾ Ambient temperature 22°C (tested at 1kHz)

²⁾ Velocity (rpm) = f (Hz) x 60/N

Features

In this version, the DC-Micromotors have an optical encoder with two output channels. A code wheel on the shaft is optically captured and further processed. At the encoder outputs, two 90° phase-shifted rectangular signals are available with 8 impulses per motor revolution.

The encoder is suitable for the monitoring and regulation of the speed and direction of rotation and for positioning the drive shaft.

The supply voltage for the encoder and the DC-Micromotor as well as the two channel output signals are interfaced through a ribbon cable with connector.

Full product description

■ Examples:

1512U003SR 6:1 IE2-8

1512U012SR 324:1 IE2-8

Output signals/Circuit diagram/Connector information

Output signals

with clockwise rotation as seen from the shaft end

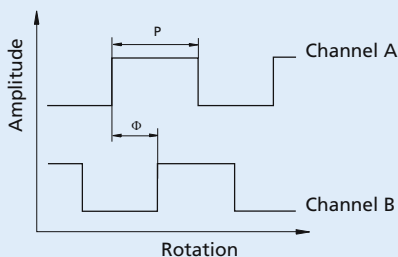

Admissible deviation of phase shift:

$$\Delta\Phi = \left| 90^\circ - \frac{\Phi}{P} * 180^\circ \right| \leq 45^\circ$$

Output circuit

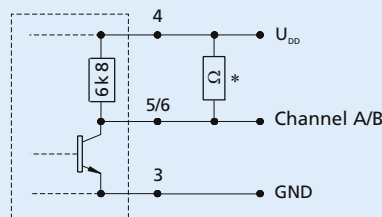

* An additional external pull-up resistor can be added to improve the rise time. Caution: I_{OUT} max. 5 mA must not be exceeded!

