

Planetary Gearheads

60 mNm

For combination with
 DC-Micromotors:
 0816
 Stepper Motors:
 AM0820

Series 08/1

	08/1	08/1 K
Housing material	metal	metal
Geartrain material	all steel	all steel
Recommended max. input speed for:		
– continuous operation	8 000 rpm	8 000 rpm
Backlash, at no-load	≤ 3°	≤ 3°
Bearings on output shaft	sintered sleeve bearings	ball bearings
Shaft load, max.:		
– radial (4,5 mm from mounting face)	≤ 0,8 N	≤ 5 N
– axial	≤ 1 N	≤ 3 N
Shaft press fit force, max.	≤ 5 N	≤ 5 N
Shaft play:		
– radial (4,5 mm from mounting face)	≤ 0,04 mm	≤ 0,06 mm
– axial	≤ 0,10 mm	≤ 0,05 mm
Operating temperature range	– 30 ... + 100 °C	– 30 ... + 100 °C

Specifications

reduction ratio	weight without motor	length without motor	length with motor		output torque		direction of rotation (reversible)	efficiency
			0816 P	AM0820	continuous operation	intermittent operation		
	g	L2 mm	L1 mm	L1 mm	M max. mNm	M max. mNm		%
4 : 1	2,9	9,6	25,6	23,4	60	120	=	90
16 : 1	3,8	12,3	28,3	26,1	60	120	=	80
64 : 1	4,6	15,0	31,0	28,8	60	120	=	70
256 : 1	5,4	17,7	33,7	31,5	60	120	=	60
1 024 : 1	6,3	20,4	36,4	34,2	60	120	=	55
4 096 : 1	7,1	23,1	39,1	36,9	60	120	=	48

M 1:1

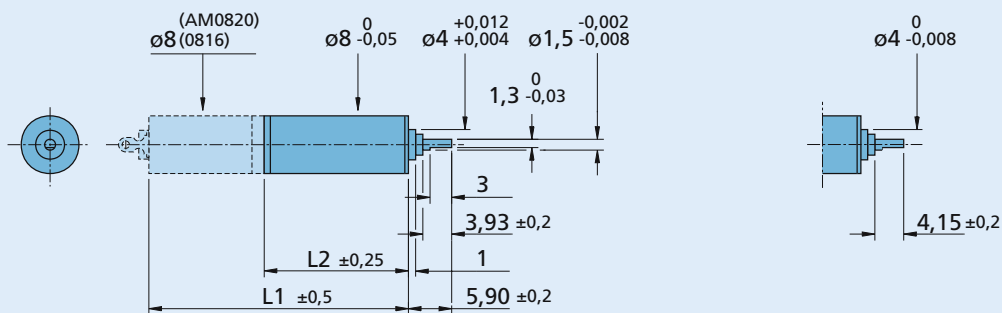

08/1

08/1 K