

Brushless Flat DC-Micromotors

penny-motor® Technology

0,2 mNm

For combination with
Gearheads:
16A
Drive Electronics:
SC 1801 F

Series 1608 ... BH

	1608 H	003 BH	
Nominal voltage	U_N	3	V
Terminal resistance, phase-phase	R	18,6	Ω
Output power ¹⁾	$P_{2 \text{ max.}}$	0,116	W
Efficiency	$\eta_{\text{ max.}}$	38	%
No-load speed	n_0	17 872	rpm
No-load current	I_0	0,032	A
Stall torque	M_H	0,203	mNm
Friction torque, static	C_0	0,005	mNm
Friction torque, dynamic	C_v	$2 \cdot 10^{-6}$	mNm/rpm
Speed constant	k_n	7 407	rpm/V
Back-EMF constant	k_E	0,135	mV/rpm
Torque constant	k_M	1,289	mNm/A
Current constant	k_I	0,776	A/mNm
Slope of n-M curve	$\Delta n / \Delta M$	106 746	rpm/mNm
Terminal inductance, phase-phase	L	21	μH
Mechanical time constant	τ_m	702	ms
Rotor inertia	J	0,628	gcm^2
Angular acceleration	$\alpha_{\text{ max.}}$	$3 \cdot 10^3$	rad/s^2
Thermal resistance	$R_{\text{th} 1} / R_{\text{th} 2}$	0 / 80	K/W
Operating temperature range		-30 ... +85	$^{\circ}\text{C}$
Shaft bearing		sintered sleeve bearings	
Shaft load max.:			
– radial at 10 000 rpm (at shaft step $\varnothing 3,4$ mm)		0,5	N
– axial at 10 000 rpm (axial push-on only)		0,1	N
– axial at standstill (axial push-on only)		20	N
Shaft play:			
– radial	\leq	0,05	mm
– axial	\leq	0,12	mm
Number of pole pairs		4	
Weight		4,1	g
Direction of rotation		electronically reversible	

Recommended values - mathematically independent of each other

Speed up to	$n_{e \text{ max.}}$	12 000	rpm
Torque up to ^{1) 2)}	$M_{e \text{ max.}}$	0,205	mNm
Thermal current up to ^{1) 2)}	$I_{e \text{ max.}}$	0,184	A

¹⁾ at 5000 rpm ²⁾ thermal resistance $R_{\text{th} 2}$ not reduced

Scale enlarged

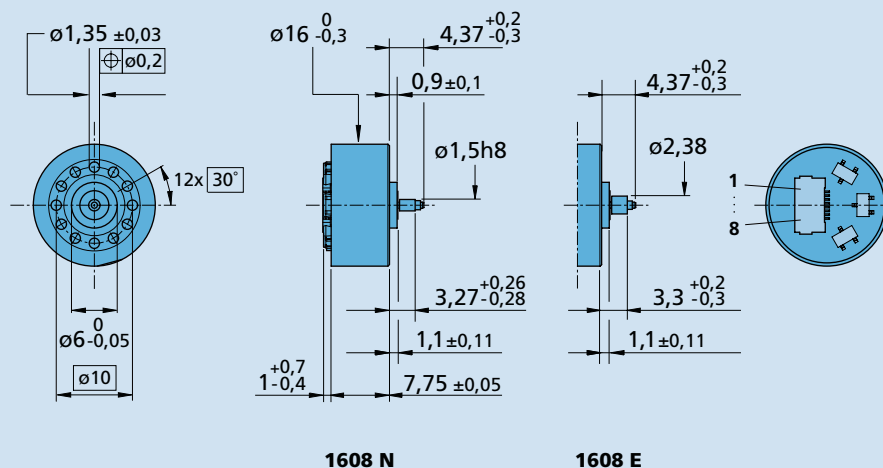

Connection

No.	Function
1	Hall sensor A
2	Hall sensor B
3	Hall sensor C
4	UDD (2.2 ... 18V DC)
5	GND
6	Phase A
7	Phase B
8	Phase C

Connectors

8-pole; 0,5 mm pitch;
thickness 0,3 mm

Accessory - optional

Adapter board with ribbon cable
Part number: 6611.00017

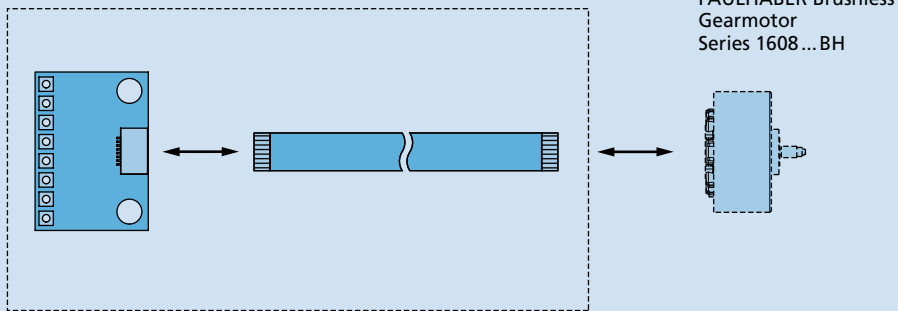

Note: The connector on the adapter board has contacts on both sides. The pin out of the adapter board depends on the orientation of the ribbon cable and motor connector.

Accessory - Dimensional drawing

M 1:1 