

LEGS-RS-10-X-S1



S



SV

Key Features

- Unlimited rotation
- High Resolution, No Backlash
- High Speed dynamics
- Electronic and manual control
- Very simple electronics
- Very compact

The Piezo LEGS[®] rotary stage is intended primarily for use in laser applications with standard 0.5inch (12.7mm) inserts. It is available in both black and bare metal versions as well as vacuum compatible.

The advantage of using the Piezo LEGS[®] technology is the unsurpassed accuracy in positioning resolution as well as automatic locking giving true set-and-forget performance. The technology is based on direct drive which removes the issues of hysteresis and backlash.

Drive Technology

The stage is using the patented Piezo LEGS[®] technology.

Controlling the stage

The range of drivers includes simple full step drivers to more advanced micro-stepping drivers that can fully utilize the excellent performance of the Piezo LEGS[®] technology. Drivers are available both from PiezoMotor as well as other independent companies (See Piezomotor.com for details). As the Piezo LEGS[®] is based on friction it is also possible to rotate the stage manually for easy course adjustment.

Ordering Information

LEGS-RS-10-S-S1	Standard
LEGS-RS-10-SV-S1	Vacuum

ACCESSORIES

PMD90	Microstep Driver
PMCM31-01	PDA3.1 Driver



PMD90

Simple electronics

For users wishing to fully integrate drivers into the overall system PiezoMotor can supply all waveforms and movement patterns to speed up the implementation. The motor is operating in a non-resonant mode and is not sensitive to cable lengths etc.

Open Loop Operation

The stage can be moved in full steps, shorter steps or partial steps (micro-stepping) giving positioning resolution of minimum 0.2 μ rad. Speed is easily adjustable from extremely low up to max specified.

Notes

The stage can be used for other applications and in other orientations. The front of the stage is supplied with mounting holes for fixing accessories.

Additional information is available upon request, info@piezomotor.com

Mechanical drawing

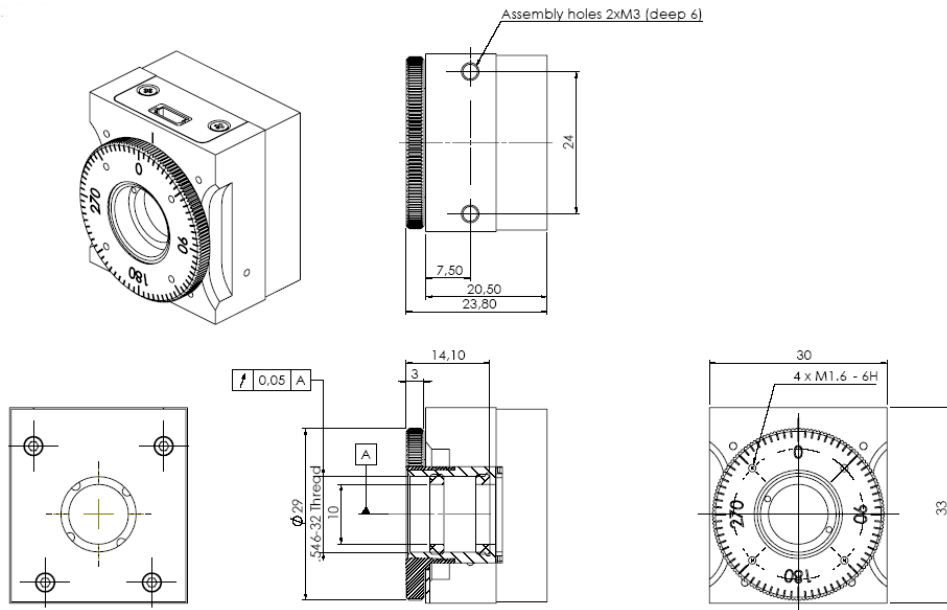

Technical Specification				
Type	LEGS-RS-10-S-S1	LEGS-RS-10-SV-S1	Unit	Note
Drawing No	RAC300-31006	RAC300-31001		
Optic Diameter	12.7 (0.5 inch)	12.7 (0.5 inch)	mm	
Angular Range	360° continuous	360° continuous	°	
Maximum Speed	140	140	°/s	
Resolution	0.2	0.2	μrad	
Stall torque	20	20	Nmm	
Holding torque	25	25	Nmm	
Life time	100.000	100.000	Nmm	1 cycle=1 revolution
Surface	Black	Bare metal	mm	See drawing for details
Mechanical size	33x30x23.8	33x30x23,8	mm	
Weight	-	-	Gram	

NOTE: All specifications are subject to change without notice.