

**NEW**

# Linear DC-Servomotors

with Analog Hall Sensors  
QUICKSHAFT® Technology

1,03 N

For combination with  
Motion Controllers:  
MCLM 3003/06 S, MCLM 3003/06 C

## Series LM 0830 ... 01

	LM 0830-	015-01	040-01		
1 Continuous force <sup>1)</sup>	F <sub>e max.</sub>	1,03		N	
2 Peak force <sup>1) 2)</sup>	F <sub>p max.</sub>	2,74		N	
3 Continuous current <sup>1)</sup>	I <sub>e max.</sub>	0,53		A	
4 Peak current <sup>1) 2)</sup>	I <sub>p max.</sub>	1,41		A	
5 Back-EMF constant	k <sub>E</sub>	1,58		V/m/s	
6 Force constant <sup>3)</sup>	k <sub>F</sub>	1,94		N/A	
7 Terminal resistance, phase-phase	R	7,37		Ω	
8 Terminal inductance, phase-phase	L	117		μH	
9 Stroke length	s <sub>max.</sub>		15	40	mm
10 Repeatability <sup>4)</sup>			40	40	μm
11 Precision <sup>4)</sup>			120	140	μm
12 Acceleration <sup>5)</sup>	a <sub>e max.</sub>		206,9	147,8	m/s <sup>2</sup>
13 Speed <sup>5) 6)</sup>	v <sub>e max.</sub>		1,8	2,4	m/s
14 Thermal resistance	R <sub>th 1</sub> / R <sub>th 2</sub>	6,6 / 37,4			K/W
15 Thermal time constant	τ <sub>w1</sub> / τ <sub>w2</sub>	4 / 291			s
16 Operating temperature range		- 20 ... +125			°C
17 Rod weight <sup>7)</sup>	m <sub>m</sub>		5	7	g
18 Total weight <sup>7)</sup>	m <sub>t</sub>		15	17	g
19 Magnetic pitch	τ <sub>m</sub>	12			mm
20 Rod bearings		polymer sleeves			
21 Housing material		metal, non-magnetic			
22 Direction of movement		electronically reversible			

<sup>1)</sup> thermal resistance R<sub>th 2</sub> by 55% reduced

<sup>2)</sup> for max. 1 second with a duty cycle of 10%

<sup>3)</sup> with sine wave commutation

<sup>4)</sup> typical values with integrated linear Hall sensors and Motion Controller MCLM 3003/06 S/C.

The values depend on conditions of use

<sup>5)</sup> theoretical value, referring only to the motor

<sup>6)</sup> with a triangular speed profile and the max. stroke

<sup>7)</sup> rounded value, for reference only

**Notes:** These motors are for operation with DC-voltage < 50 V DC.

The given values are for free standing motors.

The mounting with magnetic conductive metal can influence the characteristics of the motor.

**Caution:** Presence of strong magnetic fields. Static sensitive device.

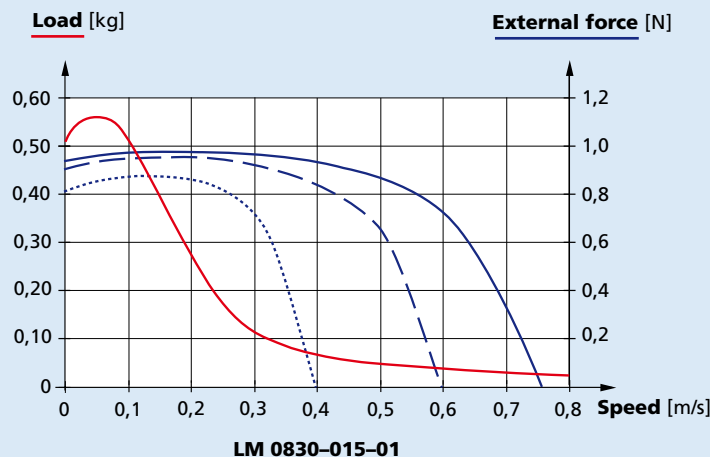

**Trapezoidal motion profile** (t<sub>1</sub> = t<sub>2</sub> = t<sub>3</sub>)

Displacement distance:	15 mm
Friction coefficient:	0,2
Slope angle:	0°
Rest time:	0,1 s

**Load:** The max. permissible load at a given speed with an external force of 0 N

**External force:** The max. permissible external force at a given speed with a load of:

- 0,035 Kg
- 0,05 Kg
- 0,1 Kg

### Linear DC-Servomotor LM 0830

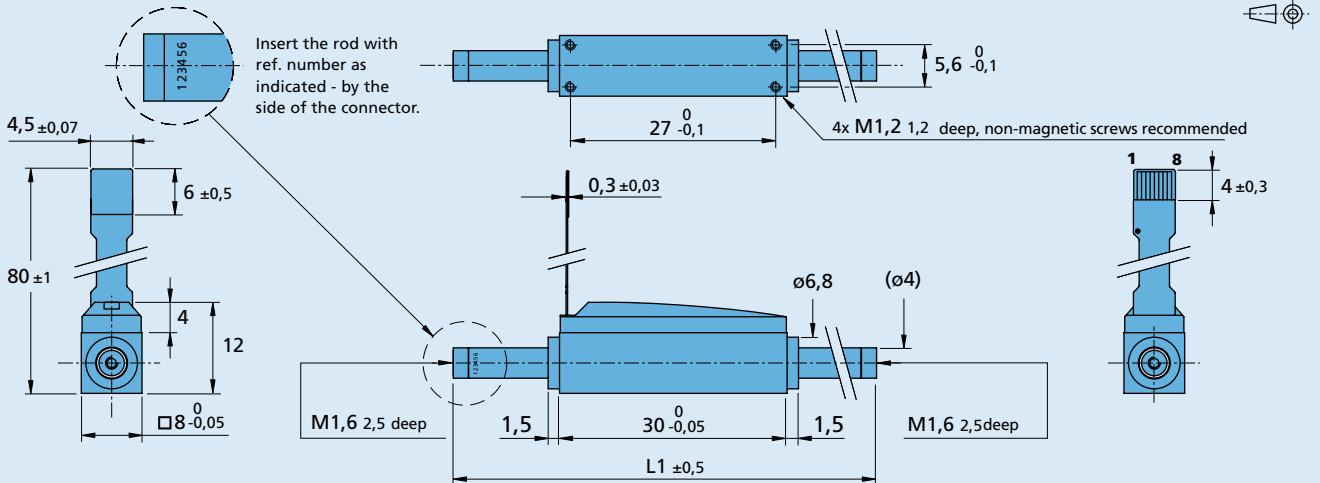

### Ordering information

#### Linear DC-Servomotors Series

Series	Stroke mm	Rod length L1 ± 0,5 mm
LM 0830-015-01	-7,5 → 0 → +7,5	58
LM 0830-040-01	-20 → 0 → +20	82

Note: Single rod available on request.

#### Options

- Flexboard adapter (part no. L08.90.02), size 18 x 23 x 6 mm
- Cable with connector (part no. L12.09.01), 200 mm length ± 10 mm, 8 conductors

### Cable and connection information

#### Motor flexboard

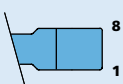

#### Flexboard adapter

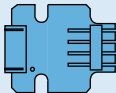

#### Cable for connection with Motion Controller

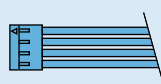

**Recommended connector**  
Molex - ZIF connector,  
Nr. 52746

**Flexboard**  
8 circuits; 0,5mm pitch

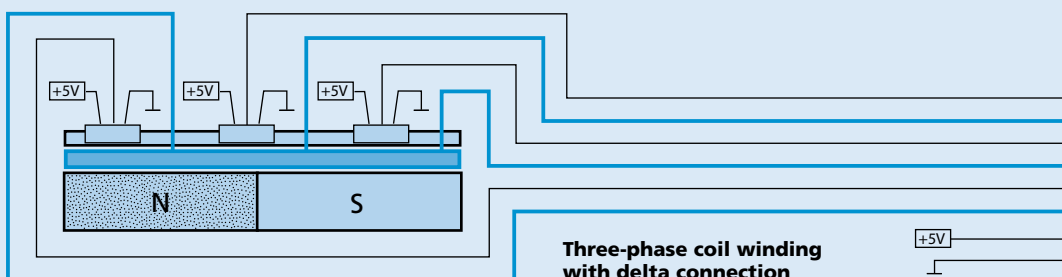

#### Connection

##### No. Function

6	Hall sensor C
1	Phase C
7	Hall sensor B
2	Phase B
8	Hall sensor A
3	Phase A
5	Logic supply +5V
4	Logic GND