

Lead Screw

Linear actuation for positioning tasks
PRECiStep® Technology

For combination with
Stepper Motors: AM0820, AM1020, ADM1220,
ADM1220S, AM1524, AM2224-R3

Series M3 x 0,5 x L1

Nominal diameter	3,0	mm
Diameter over the flanks (min./max.)	2,600 / 2,675	mm
Pitch	0,5	mm
Precision (per pitch)	< 0,5	µm
Material	316L	

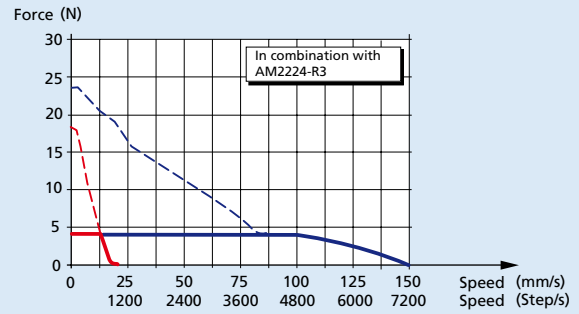
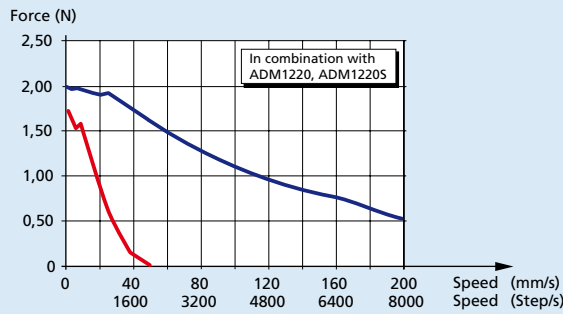
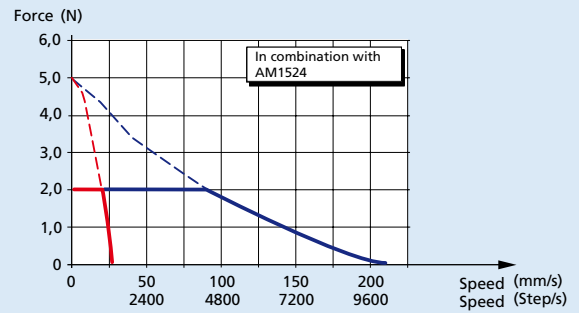
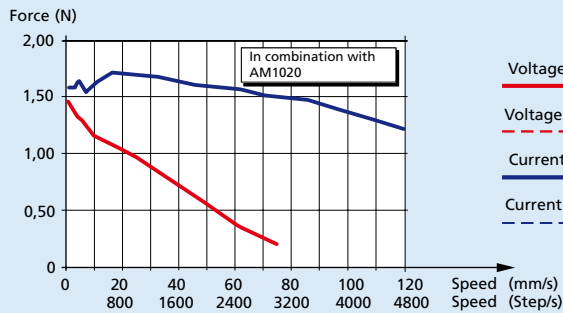

Note: the thrust curves include already a safety factor for the use of the stepper motor.

Ordering information	L1 (mm) =	15	25	Custom
Order code (no bearing tip)		M3x0,5x15	M3x0,5x25	M3x0,5xL1*
Order code (with bearing tip)		M3x0,5x15T	M3x0,5x25T	M3x0,5xL1*T

* For custom length, please inquire with your point of sales

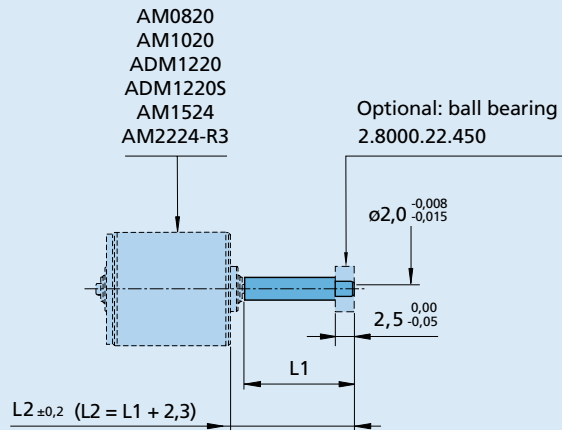
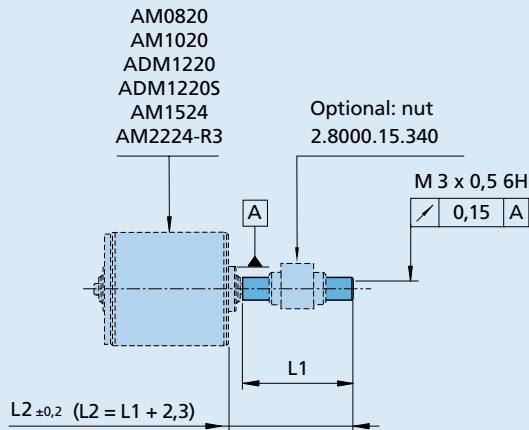

Version with bearing tip