

Brushless Flat DC-Micromotors

0,09 mNm

with integrated Position Controller and 12 Bit Encoder
penny-motor® Technology

Series 2209 T 005 B SC ...

Drive	2209 T	12 Bit	
Operating voltage	U _{DD}	2,7 ... 5,5	Volt
Standby current @ U _{DD} = 5V	I _{DD 0}	10	mA
Max. power consumption (start-up) @ U _{DD} = 5V	I _{DD max}	100	mA
Operating temperature range		-30 ... +85	°C
Shaft bearings		ball bearings, preloaded	
Shaft load max.:			
- radial at 5 000 rpm (6,2 mm from mounting flange)	1		N
- axial at 5 000 rpm (push-on only)	1		N
- axial at standstill (push-on only)	1		N
Shaft play:			
- radial	≤	0,011	mm
Housing material		aluminium	
Weight		8,5	g
Integrated motor			
Terminal resistance, phase-phase	R	40	Ω
Output power ¹⁾	P _{2 max.}	0,06	W
Efficiency	η _{max.}	13	%
No-load speed	n ₀	19 620	rpm
No-load current	I ₀	80	A
Stall torque	M _H	0,102	mNm
Friction torque, static	C ₀	0,025	mNm
Friction torque, dynamic	C _v	4,5 · 10 ⁻⁶	mNm/rpm
Speed constant	k _n	6 763	rpm/V
Back-EMF constant	k _E	0,148	mV/rpm
Torque constant	k _M	1,412	mNm/A
Current constant	k _I	0,708	A/mNm
Slope of n-M curve	Δn/ΔM	191 585	rpm/mNm
Mechanical time constant	τ _m	2 001	ms
Rotor inertia	J	1	gcm ²
Angular acceleration	α _{max.}	1,03	· 10 ³ rad/s ²
Recommended values - mathematically independent of each other			
Speed up to	n _{e max.}	10 000	rpm
Torque up to ^{2) 3)}	M _{e max.}	0,094	mNm
Max. current up to ^{2) 3)}	I _{e max.}	0,090	A

¹⁾ at 10 000 rpm ²⁾ at standstill ³⁾ thermal resistance R_{th 2} not reduced

M 1:1

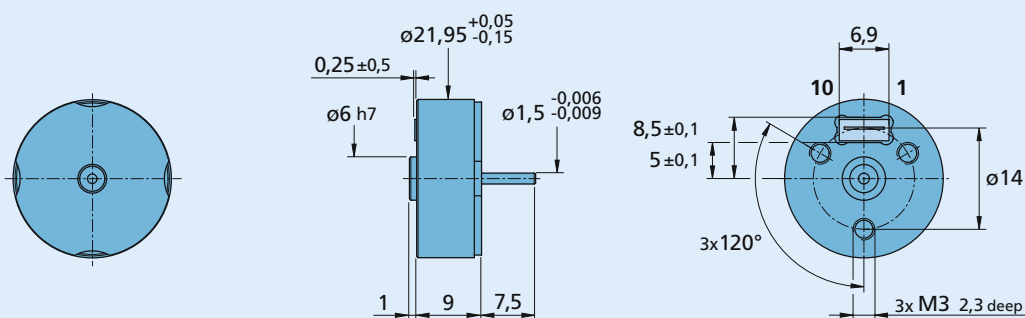

2209 T 005 B SC ...

Integrated position regulator

Steps per revolution	1 024	steps/360°
Regulator type	PID/PD	
Recovery range without step loss	± 22,5	°

Integrated encoder

Resolution	12	Bit
Precision	± 0,5	°
Reproducibility	2	LSB
Index impulse per revolution	4	pulses/360°
Absolut values angle range	90	
Absolut values margin	10	Bit

General information

A high-resolution encoder, a position regulator and an electronically commuted flat motor are integrated into the 2209T005B SC 12 Bit. This Drive System with integrated electronics performs the following functions:

Position regulation:

The target position is specified via two digital lines ("Clock" and "Direction"). The position moves on one step in the specified direction per clock impulse. The regulator is set internally, but can be modified to customer requirements as a PID regulator (special version).

A very precise synchronism can be achieved by applying an even cycle. The speed accuracy only depends on the accuracy of the specified cycle.

Even lowest speeds incl. standstill are stable controlled. The complete bidirectional speed range is continuously usable.

Integrated encoder:

The actual position of the rotor is determined by the integrated encoder and used internally for position-control and sinus-commutation.

A complete revolution is subdivided into four segments (90° each). The absolute position within one segment is measured with 10 Bit resolution. It is not possible to differentiate the segments from each other.

The encoder position can be read out externally via a digital interface. Either a quadratur interface (Qa, Qb, Index) or a serial interface (SDA, SCL, SCTL) is available. The system switches between the two types with a special input.

Speed regulator with setpoint setting by analog voltage:

A PI speed regulator (four-quadrant) with analog setpoint setting can be integrated instead of the position regulator on request (special version).

Various inputs and outputs are available:

- Using the "quadrature/serial" input, it is possible to output the encoder signal as a quadrature signal or via the serial interface.
- At the outputs "Qa" and "Qb", if the quadrature signal is selected, a 90° phase-shifted output signal is available. The index signal emits a pulse every 90° of a rotation (see diagram).
- The absolute value of the encoder can be read out via the serial interface.
- The direction of rotation of the motor can be changed using the "Direction" input. If the LOW Signal is set, the drive turns counter-clockwise. If the input is not switched on, it is set to HIGH via an internal pull-up resistance and the drive turns clockwise.
- The drive can be operated like a stepper motor using the "Clock" input: every time the flank of the input signal rises, the rotor is turned further by one position.
- If a very good synchronism is to be achieved, the "Clock" can be provided with a continuous cycle signal. The cycle of the required speed can be created directly, a ramp is not necessary, since the integrated electronic system takes over the start-up of the motor.

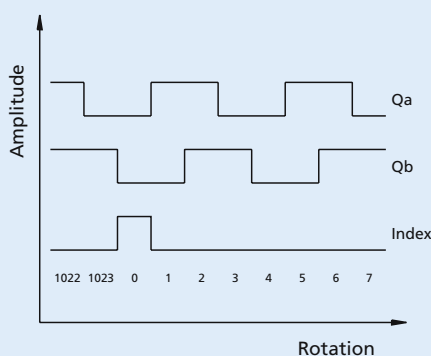
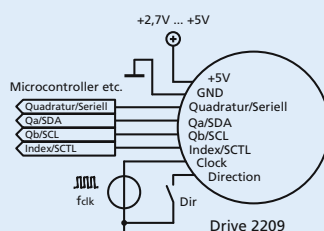
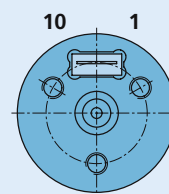
Output signals/Circuit diagram/Connector information
Output signals

Connection diagramm

Plug connection

Connection

No.	Function
1	Direction
2	Clock
3	Index/SCTL
4	Qb/SCL
5	Qa/SDA
6	(reserved)
7	(reserved)
8	Quadratur/Serial
9	GND
10	U _{DD}

Connector

FFC/FPC connector; 10-pole; 0,5 mm pitch; size 0,3 mm

Interface

Description of the serial interface

General settings:

For serial communication the two signal lines "Quadrature/Serial" and "Index/SCTL" must be connected to GND. The 2209 drive acts as slave in serial transmission, i.e. it cannot actively drive the "SCL" signal.

Start sequence:

To start communication, the "SDA" signal must be set to LOW by the master (customer-side), while "SCL" remains HIGH. After this sequence the master must switch the "SDA" signal to an input and the drive takes over the function of driving the signal.

Transmission sequence:

During data transfer 10 bits are transferred beginning with the MSB. The drive sets the new value after every falling flank of "SCL". When the 10 bits have been transferred, the drive stops controlling the "SDA" signal.

Closing sequence:

The end is characterised in that the "SDA" signal is set back to HIGH without a falling flank of the "SCL" signal. This transition must be recognised by the master. The drive is then ready for a new start sequence.

Correcting problems after data transmission:

If the "SDA" signal is not set back to HIGH automatically in the closing sequence after transmission, it is possible that the drive or master has lost the status (e.g. due to a brownout or reset). This state can be corrected by supplying the drive with a cycle at the "SCL" signal (max. 10 cycles) until the "SDA" signal changes back to HIGH.

Output signals

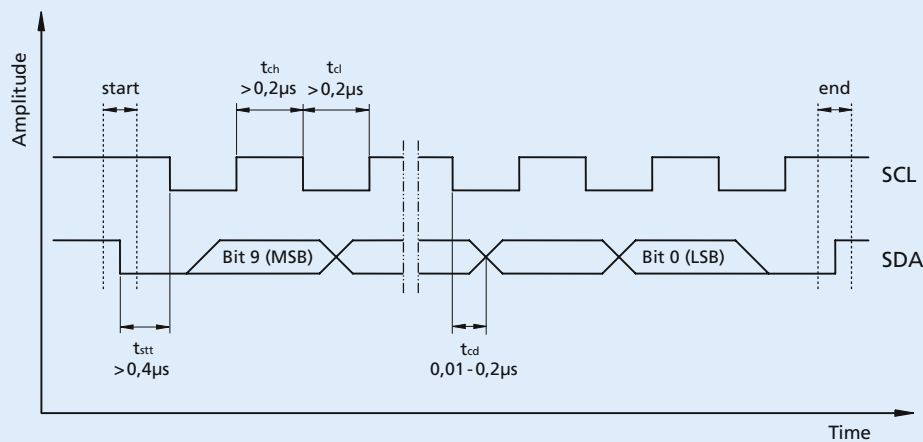

Accessory - Adapter board with ribbon cable

Accessory optional: Adapter board with ribbon cable
Part number: 6611.00016

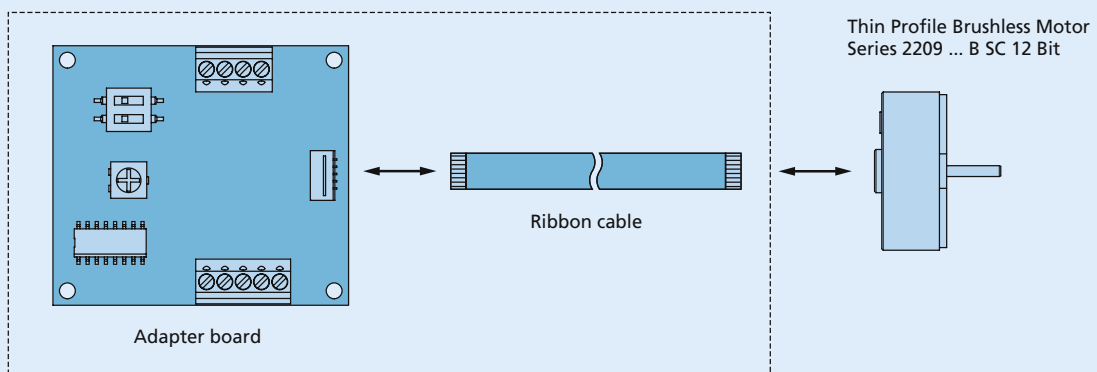
Accessory - Combination possibility
General:

The purpose of the adapter board is to facilitate quick start-up of the 2209...B SC.

The drive 2209...B SC and the adapter board are connected to each other with a 10-pin ribbon cable. The slot in the two sockets is arranged asymmetrically. The contact side of the ribbon cable must be aligned to the narrow side of the socket.

The standard assigned connections according to the aforementioned description in this datasheet are easily accessible at the adapter board via marked screw terminals. As an alternative to an external clock generator, the adapter board has an integrated oscillator.

When the oscillator has been activated, the operating voltage need only to be supplied at the screw terminals K1 "GND" and "U_{DD}" on the adapter board in order to operate the 2209...B SC.

Note: Place the adapter board on a non-conducting surface for start-up.

Integrated oscillator:

The integrated oscillator is activated (ON) and deactivated (OFF) with the DIP switch S1 "Clk". The speed of the 2209...B SC can be changed between approximately 40 rpm (potentiometer completely to the left) and approximately 2 200 rpm (potentiometer completely to the right) by turning the potentiometer P1 "Freq". The direction of rotation of the motor can be changed with the DIP switch S1 "Dir".

Motor speed:

To expand the speed range, an external frequency f_{clk} can be connected at the terminal K1 "CLK". The DIP switch S1 "Clk" must be set to position (OFF) for this.

The resultant motor speed is calculated as follows:

$$n = \frac{f_{\text{clk}}}{1024} \cdot \frac{60 \text{ sec}}{1 \text{ min}}$$

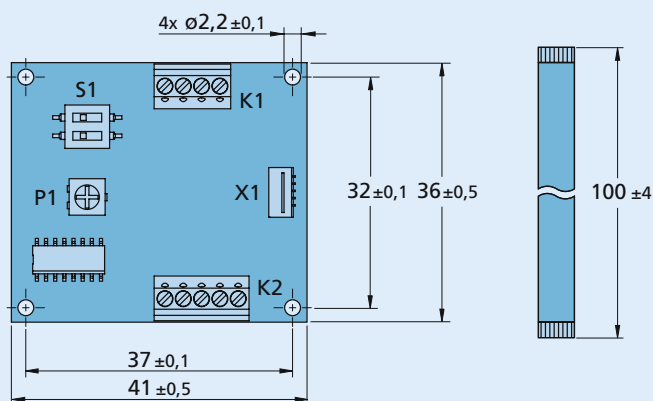
Accessory - Dimensional drawing and connection information

Connection information
Terminal K1

U _{DD}	Operating Voltage 2,7V ... 5,5V
DIR	Direction of rotation (digital input)
CLK	External clock signal (digital input)
GND	Ground

Terminal K2

Quad/Ser	Switchover encoder interface (input)	
	HIGH » Quadrature	LOW » Serial
Qa/SDA	Qa (output)	SDA (output)
Qb/SCL	Qb (output)	SCL (input)
Idx/SCTL	Index (output)	SCTL (input: LOW)
GND	Ground	

DIP switch S1

DIR	ON » direction of rotation clockwise
	OFF » direction of rotation counter clockwise
CLK	ON » integrated oscillator on
	OFF » integrated oscillator off