

Brushless DC-Servomotor

30 mNm

with integrated Drive Electronics

For combination with:
Gearheads: 30/1, 38/1, 38/2

Series 3556 K BLI

		3556 K BLI		
Nominal voltage	U_N		24	Volt
Output power	$P_{2 \text{ max.}}$		34	W
Efficiency	$\eta_{\text{ max.}}$		70	%
No-load speed	n_o		9 000	rpm
No-load current	I_o		0,35	A
Peak torque for 2,5 A	M_P		60	mNm
Torque constant	k_M		24,7	mNm/A
Current constant	k_I		0,04	A/mNm
Mechanical time constant	τ_m		26	ms
Rotor inertia	J		59	gcm ²
Angular acceleration	$\alpha_{\text{ max.}}$		54	$\cdot 10^3 \text{ rad/s}^2$
Thermal resistance	$R_{\text{th} 1} / R_{\text{th} 2}$	2,6 / 9,3		K/W
Thermal time constant	τ_{w1} / τ_{w2}	11 / 1 238		s
Operating temperature range		- 5 ... + 60		°C
Protection classification		IP 44		
Shaft bearings		ball bearings, preloaded		
Shaft load max.:				
- radial at 3000 rpm (3 mm from bearing)		100		N
- axial at 3000 rpm (axial push-on only)		50		N
- axial at standstill (axial push-on only)		30		N
Shaft play:				
- radial	\leq	0,015		mm
- axial	$=$	0		mm
Housing material		aluminium, black anodized		
Weight with electronic		400		g
Direction of rotation		electronically reversible		

Recommended values

Speed range	n_e		800 - 9 000	rpm
Torque up to	$M_{e \text{ max.}}$		30	mNm
Current up to ¹⁾	$I_{e \text{ max.}}$		1,56	A

¹⁾ thermal resistance $R_{\text{th} 2}$ by 55% reduced

Electronic

Supply voltage	U_B		22 ... 28	V DC
Peak current	$I_{\text{ max.}}$		2,5	A
Input		input resistance	390	k Ω
Set speed value, analogue			0 - 10	V
Set speed value, digital		PWM signal	low 0 ... 0,5 / high 12	V
		frequency	100	Hz
		max.speed = pulse duty factor	0	%
		speed 0 (zero) = pulse duty factor	100	%
ccw / cw rotation ²⁾			0/12	V DC
Motor operation / brake ²⁾			12/0	V DC
Fault output		open collector	max. 28 V / 30 mA	
		no error	switched to GND	

²⁾ also via isolated electrical contact: 12 V DC = open; 0 V DC = closed against GND

General description

The 3556 K BLI drive unit consists of a three phase brushless DC-Servomotor and an integrated Servo Amplifier with a P controller. The rotor, constructed of a rare earth magnet, offers high power to volume and power to weight ratios along with exceptionally high acceleration and torque capabilities.

As with all brushless DC-Servomotors, the lifetime depends on the load of the shaft bearings. The use of preloaded ball bearings, allows a lifetime of approx. 20 000 hours for the unit in question.

Servo Amplifier with P controller integrated and protected.

Fault monitoring

Fault output via open collector. The following functions are monitored: Overcurrent, overtemperature and Hall sensors.

Speed Control with a PWM-Signal

The desired speed will be given as the pulse duty ratio of the square wave voltage.

Set speed value

The value can be set with an external voltage of 0 - 10 V DC or with a pulse-width modulated signal.

Direction of rotation

The direction of rotation is set with a digital signal or an isolated electrical contact.

Motor brake

Motor brake is set with a digital signal or an isolated electrical contact.

Wire breakage

With the logic inputs inactivated, a respective value of approx. 5 V is measurable and therefore, a possible wire breakage can be determined.

Area of Application

Ease of installation, integrated technology, and size allow this Motor to perform to under severe conditions with long lifetime in a wide range of applications, for example, in decentralized automated production systems like handling or tooling machines.

3556 K BLI

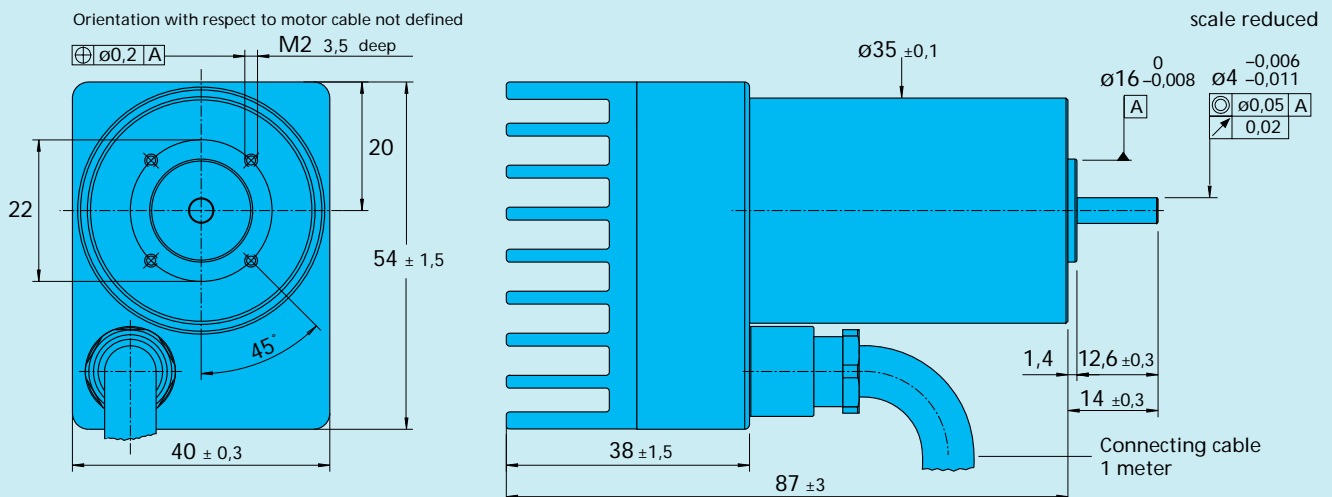

Motor characteristic curves

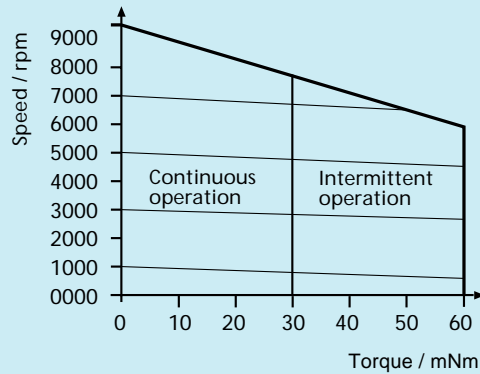

The connections are colored leads which are assigned as follows:

Lead	Description
blue	GND
pink	+ 24 V
green	Brake input
yellow	CW / CCW rotation
brown	Set speed, analog
grey	Set speed, PWM
white	Fault output

Caution:

be sure to connect motor supply terminals to the correct polarity. Motor electronics are protected against polarity reversal by an internal fuse. In case of damage due to polarity reversal, this internal fuse can only be replaced at the factory.

Hints for using

Analog set speed value

The value of the speed can be set from 0 to full via the analog set speed value input. In the illustration 0 to 10 V of the 24 V supply voltage are put to the analog input via a voltage divider.

- 0 V.... speed zero
- 5 V.... half speed
- 10 V.... full speed

General hints

In order to operate the unit at full speed simply connect the blue lead to GND the pink lead to 24 V DC and the PWM set speed value grey lead also to GND. The other pins are internally connected and do not have to be wired in this case. To use the full motor dynamics, a power unit of at least 5 A should be available.

Fault output

The Fault output, via open-collector, goes High (i.e. 24 V DC) when one or more of the following conditions occur: overcurrent, overtemperature and Hall sensor problem.

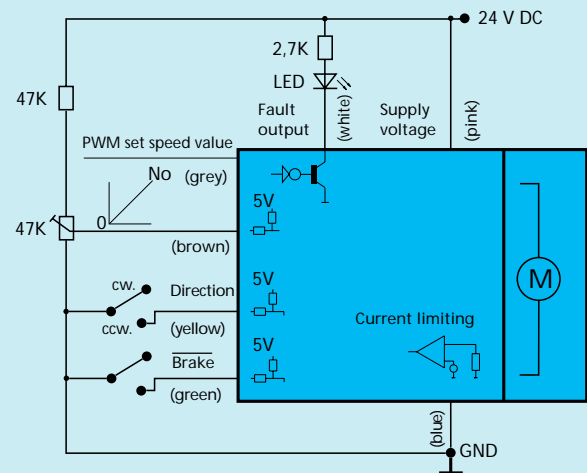

Speed value set with PWM signal

PWM signal to set speed value:

