

DC-Motor-Tacho Combinations

110 mNm

Graphite Commutation

For combination with:
Gearheads:
38/1, 38/2

Series 3863 ... C

Characteristics of the DC-Motor-Tacho Combination

Series	mechanical time constant	moment of inertia	angular acceleration	frequency	weight response
3863 H 012 C 4,3 G	τ_m 6 ms	111,65 gcm ²	$\alpha_{max.}$ $108 \cdot 10^3 \text{ rad s}^{-2}$	870 Hz	449 g
3863 H 024 C 4,3 G	6 ms	111,65 gcm ²	$118 \cdot 10^3 \text{ rad s}^{-2}$	870 Hz	449 g
3863 H 048 C 4,3 G	6 ms	111,65 gcm ²	$118 \cdot 10^3 \text{ rad s}^{-2}$	870 Hz	449 g

The characteristics of the DC-Micromotor Series 3863 ... C, used for these combinations are listed on page 61.

Tachogenerator		4,3 G	
EMF constant	K_E	4,3	mV/rpm
		41,1	mV/rad s ⁻¹
Tolerance of EMF constant		± 1	%
Load resistance	R_L	≥ 25	kΩ
Operating speed, max. continuous	$n_{e \text{ max.}}$	≤ 5000	rpm
Terminal resistance	R	260	Ω
Ripple, peak-peak, typical		7	%
Ripple frequency, cycles		14	per turn
Linearity, without load, between 500 and 5000 rpm		± 0,2	%
Reversion error		± 0,2	%
Temperature coefficient of EMF		0,02	% / °C
Temperature coefficient of armature resistance		0,4	% / °C
Rotor inductance	L	7000	μH
Direction of rotation		reversible	
Polarity		dependent on direction of rotation	

Features

Mono-axis design

Motor and tachogenerator feature the patented skew wound ironless rotors (System FAULHABER®). The mono-axis design with the two commutator systems, facing each other in a patented arrangement, mounted on a single solid shaft, has excellent torsion characteristics and the highest frequency response possible.

Commutation system

The motors are built with copper commutators and the copper impregnated graphite brushes. The tachogenerator have commutators and brushes made of gold alloy to assure a high quality output signal.

Operating temperature ranges:

Motor-Tacho, standard -30 ... + 125 °C
Rotor, max. permissible + 155 °C

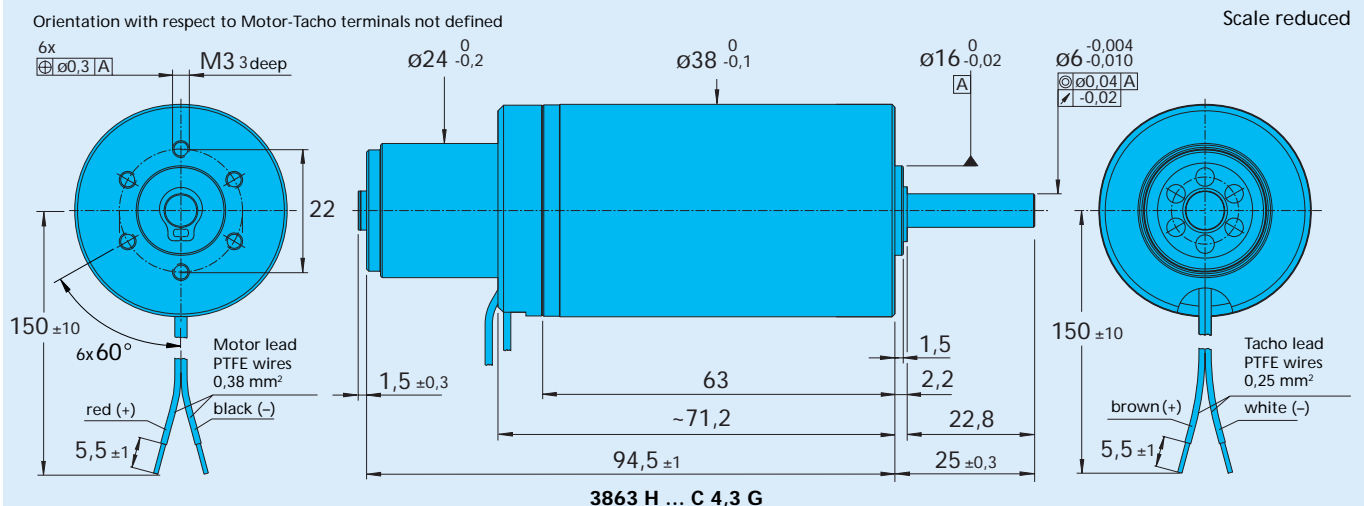

For notes on technical data and lifetime performance refer to "Technical Information".

Specifications subject to change without notice.